



ESP-12E WiFi Module

Version1.0

Disclaimer and Copyright Notice.

Information in this document, including URL references, is subject to change without notice.

THIS DOCUMENT IS PROVIDED AS IS WITH NO WARRANTIES WHATSOEVER, INCLUDING ANY WARRANTY OF MERCHANTABILITY, NON-INFRINGEMENT, FITNESS FOR ANY PARTICULAR PURPOSE, OR ANY WARRANTY OTHERWISE ARISING OUT OF ANY PROPOSAL, SPECIFICATION OR SAMPLE. All liability, including liability for infringement of any proprietary rights, relating to use of information in this document is disclaimed. No licenses express or implied, by estoppel or otherwise, to any intellectual property rights are granted herein.

The WiFi Alliance Member Logo is a trademark of the WiFi Alliance.

All trade names, trademarks and registered trademarks mentioned in this document are property of their respective owners, and are hereby acknowledged.

Copyright © 2015 AI-Thinker team. All rights reserved.

Notice

Product version upgrades or other reasons, possible changes in the contents of this manual. AI-Thinker reserves in the absence of any notice or indication of the circumstances the right to modify the content of this manual. This manual is used only as a guide, AI-thinker make every effort to provide accurate information in this manual, but AI-thinker does not ensure that manual content without error, in this manual all statements, information and advice nor does it constitute any express or implied warranty.



Table of Contents

1. Preambles	3
1.1. Features	4
1.2. Parameters	6
2. Pin Descriptions	7
3. Packaging and Dimension	9
4. Functional Descriptions	11
4.1. MCU	11
4.2. Memory Organization	11
4.2.1. Internal SRAM and ROM	11
4.2.2. External SPI Flash	11
4.3. Crystal	12
4.4. Interfaces	12
4.5. Absolute Maximum Ratings	14
4.6. Recommended Operating Conditions	14
4.7. Digital Terminal Characteristics	14
5. RF Performance	15
6. Power Consumption	16
7. Reflow Profile	17
8. Schematics	18



1. Preambles

ESP-12E WiFi module is developed by Ai-thinker Team. core processor ESP8266 in smaller sizes of the module encapsulates Tensilica L106 integrates industry-leading ultra low power 32-bit MCU micro, with the 16-bit short mode, Clock speed support 80 MHz, 160 MHz, supports the RTOS, integrated Wi-Fi MAC/BB/RF/PA/LNA, on-board antenna.

The module supports standard IEEE802.11 b/g/n agreement, complete TCP/IP protocol stack. Users can use the add modules to an existing device networking, or building a separate network controller.

ESP8266 is high integration wireless SOCs, designed for space and power constrained mobile platform designers. It provides unsurpassed ability to embed Wi-Fi capabilities within other systems, or to function as a standalone application, with the lowest cost, and minimal space requirement.

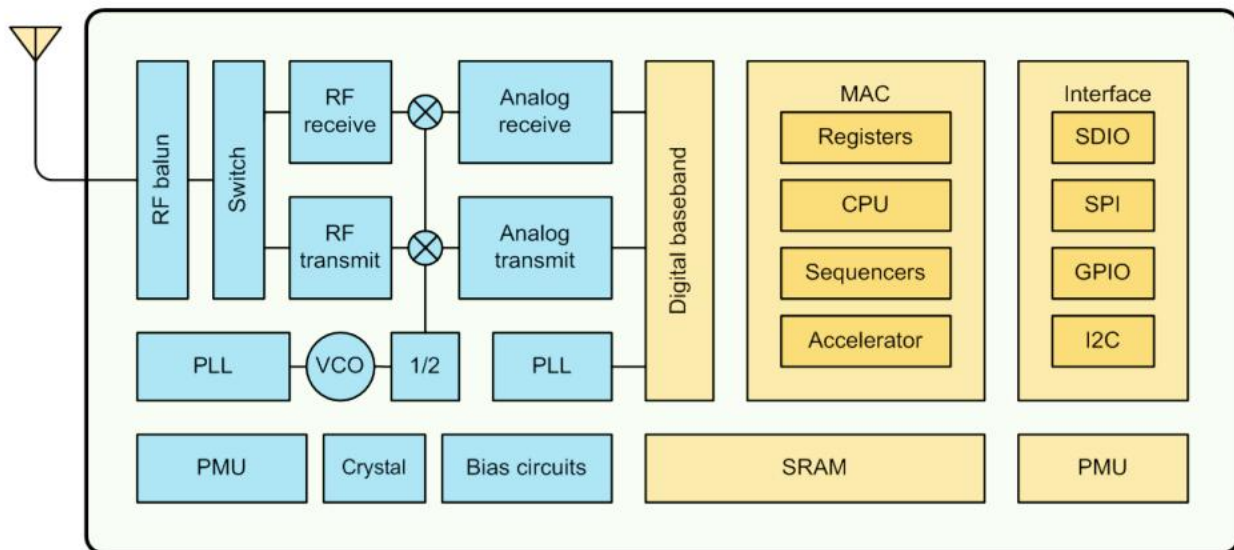

Figure 1 ESP8266EX Block Diagram

ESP8266EX offers a complete and self-contained Wi-Fi networking solution; it can be used to host the application or to offload Wi-Fi networking functions from another application processor.

When ESP8266EX hosts the application, it boots up directly from an external flash. It has integrated cache to improve the performance of the system in such applications.

Alternately, serving as a Wi-Fi adapter, wireless internet access can be added to any micro controller based design with simple connectivity (SPI/SDIO or I2C/UART interface).

ESP8266EX is among the most integrated WiFi chip in the industry; it integrates the antenna switches, RF balun, power amplifier, low noise receive amplifier, filters, power management modules, it requires minimal external circuitry, and the entire solution, including front-end module, is designed to occupy minimal PCB area.



ESP8266EX also integrates an enhanced version of Tensilica's L106 Diamond series 32-bit processor, with on-chip SRAM, besides the Wi-Fi functionalities. ESP8266EX is often integrated with external sensors and other application specific devices through its GPIOs; codes for such applications are provided in examples in the SDK.

Espressif Systems' Smart Connectivity Platform (ESCP) demonstrates sophisticated system-level features include fast sleep/wake context switching for energy-efficient VoIP, adaptive radio biasing. for low-power operation, advance signal processing, and spur cancellation and radio co-existence features for common cellular, Bluetooth, DDR, LVDS, LCD interference mitigation.

1.1. Features

- 802.11 b/g/n
- Integrated low power 32-bit MCU
- Integrated 10-bit ADC
- Integrated TCP/IP protocol stack
- Integrated TR switch, balun, LNA, power amplifier and matching network
- Integrated PLL, regulators, and power management units
- Supports antenna diversity
- Wi-Fi 2.4 GHz, support WPA/WPA2
- Support STA/AP/STA+AP operation modes
- Support Smart Link Function for both Android and iOS devices
- Support Smart Link Function for both Android and iOS devices
- SDIO 2.0, (H) SPI, UART, I2C, I2S, IRDA, PWM, GPIO
- STBC, 1x1 MIMO, 2x1 MIMO
- A-MPDU & A-MSDU aggregation and 0.4s guard interval



- Deep sleep power $< 10\mu\text{A}$, Power down leakage current $< 5\mu\text{A}$
- Wake up and transmit packets in $< 2\text{ms}$
- Standby power consumption of $< 1.0\text{mW}$ (DTIM3)
- $+20\text{dBm}$ output power in 802.11b mode
- Operating temperature range $-40\text{C} \sim 125\text{C}$



1.2. Parameters

Table 1 below describes the major parameters.

Table 1 Parameters

Categories	Items	Values
WiFi Paramters	WiFi Protocles	802.11 b/g/n
	Frequency Range	2.4GHz-2.5GHz (2400M-2483.5M)
Hardware Paramaters	Peripheral Bus	UART/HSPI/I2C/I2S/Ir Remote Contorl
		GPIO/PWM
	Operating Voltage	3.0~3.6V
	Operating Current	Average value: 80mA
	Operating Temperature Range	-40°~125°
	Ambient Temperature Range	Normal temperature
	Package Size	16mm*24mm*3mm
	External Interface	N/A
Software Paramaters	Wi-Fi mode	station/softAP/SoftAP+station
	Security	WPA/WPA2
	Encryption	WEP/TKIP/AES
	Firmware Upgrade	UART Download / OTA (via network) / download and write firmware via host
	Ssoftware Development	Supports Cloud Server Development / SDK for custom firmware development
	Network Protocols	IPv4, TCP/UDP/HTTP/FTP
	User Configuration	AT Instruction Set, Cloud Server, Android/iOS App



2. Pin Descriptions

There are altogether 22 pin counts, the definitions of which are described in Table 2 below.

Table 2 ESP-12E Pin design

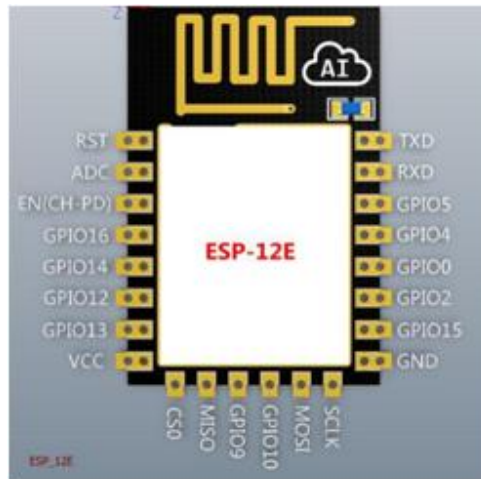

Table 3 Pin Descriptions

NO.	Pin Name	Function
1	RST	Reset the module
2	ADC	A/D Conversion result. Input voltage range 0-1v, scope: 0-1024
3	EN	Chip enable pin. Active high
4	IO16	GPIO16; can be used to wake up the chipset from deep sleep mode.
5	IO14	GPIO14; HSPI_CLK
6	IO12	GPIO12; HSPI_MISO
7	IO13	GPIO13; HSPI_MOSI; UART0_CTS
8	VCC	3.3V power supply (VDD)
9	CS0	Chip selection
10	MISO	Salve output Main input



11	IO9	GPIO9
12	IO10	GBIO10
13	MOSI	Main output slave input
14	SCLK	Clock
15	GND	GND
16	IO15	GPIO15; MTDO; HSPICS; UART0_RTS
17	IO2	GPIO2; UART1_TXD
18	IO0	GPIO0
19	IO4	GPIO4
20	IO5	GPIO5
21	RXD	UART0_RXD; GPIO3
22	TXD	UART0_TXD; GPIO1

Table 4 Pin Mode

Mode	GPIO15	GPIO0	GPIO2
UART	Low	Low	High
Flash Boot	Low	High	High



Table 5 Receiver Sensitivity

Parameters	Min	Typical	Max	Unit
Input frequency	2412		2484	MHz
Input impedance		50		Ω
Input reflection			-10	dB
Output power of PA for 72.2Mbps	15.5	16.5	17.5	dBm
Output power of PA for 11b mode	19.5	20.5	21.5	dBm
Sensitivity				
DSSS, 1Mbps		-98		dBm
CCK, 11Mbps		-91		dBm
6Mbps (1/2 BPSK)		-93		dBm
54Mbps (3/4 64-QAM)		-75		dBm
HT20, MCS7 (65Mbps, 72.2Mbps)		-72		dBm
Adjacent Channel Rejection				
OFDM, 6Mbps		37		dB
OFDM, 54Mbps		21		dB
HT20, MCS0		37		dB
HT20, MCS7		20		dB

3. Packaging and Dimension

The external size of the module is 16mm*24mm*3mm, as is illustrated in Figure 3 below. The type of flash integrated in this module is an SPI flash, the capacity of which is 4 MB, and the package size of which is SOP-210mil. The antenna applied on this module is a 3DBi PCB-on-board antenna.



Figure 3 [Module Pin Counts, 22 pin, 16 mm *24 mm *3 mm]

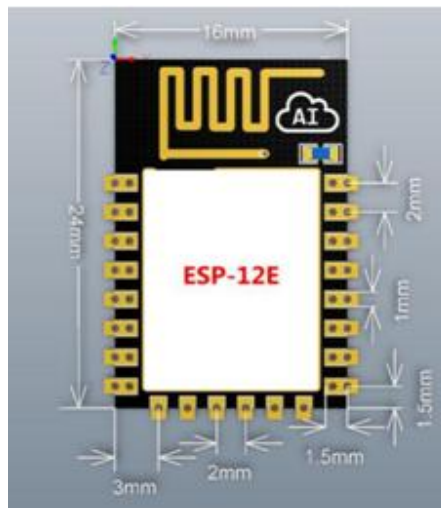

Figure 4 Top View of ESP-12E WiFi Module



Table 5 Dimension of ESP-12E WiFi Modul

Length	Width	Height	PAD Size(Bottom)	Pin Pitch
16 mm	24mm	3 mm	0.9 mm x 1.7 mm	2mm

4. Functional Descriptions

4.1. MCU

ESP8266EX is embedded with Tensilica L106 32-bit micro controller (MCU), which features extra low power consumption and 16-bit RSIC. The CPU clock speed is 80MHz. It can also reach a maximum value of 160MHz. ESP8266EX is often integrated with external sensors and other specific devices through its GPIOs; codes for such applications are provided in examples in the SDK.

4.2. Memory Organization

4.2.1. Internal SRAM and ROM

ESP8266EX WiFi SoC is embedded with memory controller, including SRAM and ROM. MCU can visit the memory units through iBus, dBus, and AHB interfaces. All memory units can be visited upon request, while a memory arbiter will decide the running sequence according to the time when these requests are received by the processor.

According to our current version of SDK provided, SRAM space that is available to users is assigned as below:

- RAM size < 36kB, that is to say, when ESP8266EX is working under the station mode and is connected to the router, programmable space accessible to user in heap and data section is around 36kB.)
- There is no programmable ROM in the SoC, therefore, user program must be stored in an external SPI flash.

4.2.2. External SPI Flash

This module is mounted with an 4 MB external SPI flash to store user programs. If larger definable storage space is required, a SPI flash with larger memory size is preferred. Theoretically speaking, up to 16 MB memory capacity can be supported.

Suggested SPI Flash memory capacity:

- OTA is disabled: the minimum flash memory that can be supported is 512 kB;
- OTA is enabled: the minimum flash memory that can be supported is 1 MB.

Several SPI modes can be supported, including Standard SPI, Dual SPI, and Quad SPI.



Therefore, please choose the correct SPI mode when you are downloading into the flash, otherwise firmwares/programs that you downloaded may not work in the right way.

4.3. Crystal

Currently, the frequency of crystal oscillators supported include 40MHz, 26MHz and 24MHz. The accuracy of crystal oscillators applied should be $\pm 10\text{PPM}$, and the operating temperature range should be between -20°C and 85°C .

When using the downloading tools, please remember to select the right crystal oscillator type. In circuit design, capacitors C1 and C2, which are connected to the earth, are added to the input and output terminals of the crystal oscillator respectively. The values of the two capacitors can be flexible, ranging from 6pF to 22pF, however, the specific capacitive values of C1 and C2 depend on further testing and adjustment on the overall performance of the whole circuit. Normally, the capacitive values of C1 and C2 are within 10pF if the crystal oscillator frequency is 26MHz, while the values of C1 and C2 are $10\text{pF} < \text{C1}, \text{C2} < 22\text{pF}$ if the crystal oscillator frequency is 40MHz.

4.4. Interfaces

Table 6 Descriptions of Interfaces

Interface	Pin Name	Description
HSPI	IO12(MISO) IO13(MOSI) IO14(CLK) IO15(CS)	SPI Flash 2, display screen, and MCU can be connected using HSPI interface.
PWM	IO12(R) IO15(G) IO13(B)	Currently the PWM interface has four channels, but users can extend the channels according to their own needs. PWM interface can be used to control LED lights, buzzers, relays, electronic machines, and so on.
IR Remote Control	IO14(IR_T) IO5(IR_R)	The functionality of Infrared remote control interface can be implemented via software programming. NEC coding, modulation, and demodulation are used by this interface. The frequency of modulated carrier signal is 38KHz.
ADC	TOUT	ESP8266EX integrates a 10-bit analog ADC. It can be used to test the power-supply voltage of VDD3P3 (Pin3 and Pin4) and the input power voltage of TOUT (Pin 6). However, these two functions cannot be used simultaneously. This interface is typically used in sensor products.
I2C	IO14(SCL) IO2(SDA)	I2C interface can be used to connect external sensor products and display screens, etc.



Interface	Pin Name	Description
UART	UART0: TXD (U0TXD) RXD (U0RXD) IO15 (RTS) IO13 (CTS) UART1: IO2(TXD)	<p>Devices with UART interfaces can be connected with the module.</p> <p>Downloading: U0TXD+U0RXD or GPIO2+U0RXD</p> <p>Communicating: UART0: U0TXD, U0RXD, MTDO (U0RTS), MTCK (U0CTS)</p> <p>Debugging: UART1_TXD (GPIO2) can be used to print debugging information.</p> <hr/> <p>By default, UART0 will output some printed information when the device is powered on and is booting up. If this issue exerts influence on some specific applications, users can exchange the inner pins of UART when initializing, that is to say, exchange U0TXD, U0RXD with U0RTS, U0CTS.</p>
I2S	I2S Input: IO12 (I2SI_DATA) ; IO13 (I2SI_BCK); IO14 (I2SI_WS); I2S Output: IO15 (I2SO_BCK); IO3 (I2SO_DATA); IO2 (I2SO_WS).	<p>I2S interface is mainly used for collecting, processing, and transmission of audio data.</p>



4.5. Absolute Maximum Ratings

Table 7 Absolute Maximum Ratings

Rating	Condition	Value	Unit
Storage Temperature		-40 to 125	°C
Maximum Soldering Temperature		260	°C
Supply Voltage	IPC/JEDEC J-STD-020	+3.0 to +3.6	V

4.6. Recommended Operating Conditions

Table 8 Recommended Operating Conditions

Operating Condition	Symbol	Min	Typ	Max	Unit
Operating Temperature		-40	20	125	°C
Supply voltage	VDD	3.0	3.3	3.6	V

4.7. Digital Terminal Characteristics

Table 9 Digital Terminal Characteristics

Terminals	Symbol	Min	Typ	Max	Unit
Input logic level low	V _{IL}	-0.3		0.25VDD	V
Input logic level high	V _{IH}	0.75VDD		VDD+0.3	V
Output logic level low	V _{OL}	N		0.1VDD	V
Output logic level high	V _{OH}	0.8VDD		N	V

Note: Test conditions: VDD = 3.3V, Temperature = 20 °C, if nothing special is stated.



5. RF Performance

Description	Min.	Typ.	Max	Unit
Input frequency	2400		2483.5	MHz
Input impedance		50		ohm
Input reflection			-10	dB
Output power of PA for 72.2Mbps	15.5	16.5	17.5	dBm
Output power of PA for 11b mode	19.5	20.5	21.5	dBm
Sensitivity				
CCK, 1Mbps		-98		dBm
CCK, 11Mbps		-91		dBm
6Mbps (1/2 BPSK)		-93		dBm
54Mbps (3/4 64-QAM)		-75		dBm
HT20, MCS7 (65Mbps, 72.2Mbps)		-72		dBm
Adjacent Channel Rejection				
OFDM, 6Mbps		37		dB
OFDM, 54Mbps		21		dB
HT20, MCS0		37		dB
HT20, MCS7		20		dB

Table 10 RF Performance



6. Power Consumption

Parameters	Min	Typical	Max	Unit
Tx802.11b, CCK 11Mbps, P OUT=+17dBm		170		mA
Tx 802.11g, OFDM 54Mbps, P OUT =+15dBm		140		mA
Tx 802.11n, MCS7, P OUT =+13dBm		120		mA
Rx 802.11b, 1024 bytes packet length , -80dBm		50		mA
Rx 802.11g, 1024 bytes packet length, -70dBm		56		mA
Rx 802.11n, 1024 bytes packet length, -65dBm		56		mA
Modem-Sleep ^①		15		mA
Light-Sleep ^②		0.9		mA
Deep-Sleep ^③		10		uA

Table 11 Power Consumption

- ① Modem-Sleep requires the CPU to be working, as in PWM or I2S applications. According to 802.11 standards (like U-APSD), it saves power to shut down the Wi-Fi Modem circuit while maintaining a Wi-Fi connection with no data transmission. E.g. in DTIM3, to maintain a sleep 300ms-wake 3ms cycle to receive AP's Beacon packages, the current is about 15mA.
- ② During Light-Sleep, the CPU may be suspended in applications like Wi-Fi switch. Without data transmission, the Wi-Fi Modem circuit can be turned off and CPU suspended to save power according to the 802.11 standard (U-APSD). E.g. in DTIM3, to maintain a sleep 300ms-wake 3ms cycle to receive AP's Beacon packages, the current is about 0.9mA.
- ③ Deep-Sleep does not require Wi-Fi connection to be maintained. For application with long time lags between data transmission, e.g. a temperature sensor that checks the temperature every 100s ,sleep 300s and waking up to connect to the AP (taking about 0.3~1s), the overall average current is less than 1mA.



7. Reflow Profile

Table 12 Instructions

T_S max to T_L (Ramp-up Rate)	3°C/second max
Preheat Temperature Min.(T_S Min.) Temperature Typical.(T_S Typ.) Temperature Min.(T_S Max.) Time(T_S)	150°C 175°C 200°C 60~180 seconds
Ramp-up rate (T_L to T_P)	3°C/second max
Time Maintained Above: --Temperature(T_L)/Time(T_L)	217°C/60~150 seconds
Peak Temperature(T_P)	260°C max. for 10 seconds
Target Peak Temperature (T_P Target)	260°C +0/-5°C
Time within 5°C of actual peak(t_P)	20~40 seconds
T_S max to T_L (Ramp-down Rate)	6°C/second max
Tune 25°C to Peak Temperature (t)	8 minutes max



8. Schematics

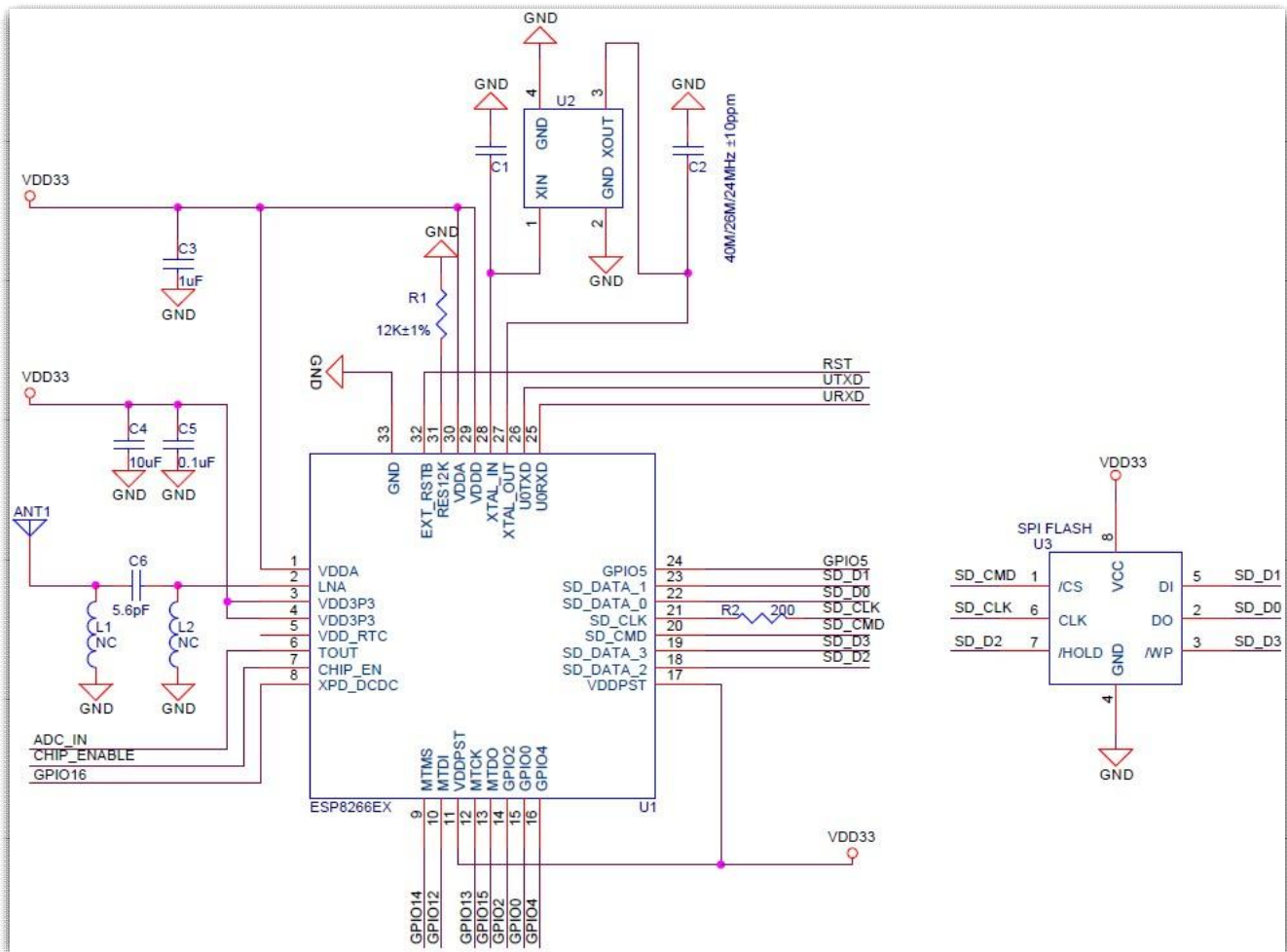

Figure 4 Schematics of Esp-12E WiFi Module