

## Oil Burner Safety Control

For 1- or 2-stage oil power burners up to 30kg/h capacity and intermittent operations.

### Flame detection:

- Photoresistor FZ 771 S
- Infrared-flicker detector IRD 1010
- UV solid state sensor UVD 970

### APPLICATION RANGE

The TF 804 oil burner safety control box is suitable to control and monitor oil power burner with or without oil preheaters up to 30 kg/h capacity (approved and certified according to DIN 4787). The control boxes TF 804.2 is approved and certified according to EN230.

### TYPES AVAILABLE

TF 804	1-stage operation post-ignition time ca. 3-5 sec.
TF 804.2	1-stage operation post-ignition time ca. 3-5 sec. low voltage protection according to EN230

### CONSTRUCTIONAL FEATURES

The control box circuitry is protected by a flame resistant, transparent plastic housing. It incorporates the thermo-mechanical, temperature compensated timer, flame check and reset circuits.

Manual reset from lockout is provided by a push button with an integrated lockout signal lamp. A central fixing screw locks the control box to the wiring base. The wiring base and control box have a positive plug-in arrangement, making it impossible to achieve an incorrect connection between the two parts. A variety of cable entry points provides utmost flexibility of electrical wiring.

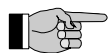

The TF 804.2 is fully compatible with the TF 704 and TF 804. The flame detector IRD 910 must be replaced by its compatible type IRD 1010. An optional extension button (item no. 70601) compensates for height differences.



### TECHNICAL DATA

Operating voltage	220/240V (-15..+10%) 50 Hz (40-60Hz)
Fuse rating	10 A fast, 6 A slow
Power consumption	ca. 5 VA
Max. load per output	
- terminal 3	1.5 A, cos φ 0.2
- terminal 4	4 A, cos φ 0.4
- terminal 5	0.5 A, cos φ 0.4
- terminal 6	4 A, cos φ 0.4
- terminal 7	0.1 A, cos φ 0.4
total load	5A, cos φ 0.4
Pre-purge time	ca. 12 sec.
Pre-ignition time	ca. 12 sec.
Post-ignition time	ca. 3-5 sec.
Lockout safety time	10 sec.
Reset time from lockout	ca. 60 sec
Flame detector:	
FZ 771 S red	side-on viewing
FZ 771 S white	side-on and end-on viewing
Light sensitivity FZ 711S IRD 1010	> 10 Lux side-on or end-on viewing
UVD 970	end-on viewing
Weight incl. wiring base	0.25 kg
Mounting position	any
Protection class	IP44
Recommended ambient operating temperature for control and flame detector	0°C...+60°C
approved and certified according to European standards	
TF 804.2	EN 230
TF 804	DIN 4787

## APPLICATION NOTES

### 1. Flame control

The following detectors can be used for flame control:

- For yellow oil flame: photoresistor FZ 771 S (red inscription: side-on; white inscription: side-on and end-on viewing)
- for blue or yellow flame: infrared-flicker detector type IRD 1010 or as alternative the UV solid state sensor UVD 970.

Using the photo resistor FZ 711 S, the no flame signal is generated at light levels below 3 Lux with respect to the operating cycle of the control. According to DIN74787 and EN 230 stray light safety level has to be established in conjunction with the accompanying burner.

Connecting the IRD 1010 or the UVD 970, the correct wiring has to be observed.

### 2. Burner control

With oil preheater:

- The fuel heater of the burner must have a temperature control switch. The closing contact-switch of the preheater has to be connected between terminals 4 and 6. A special contact in the control unit-connects the thermo-switch of the heater as soon as the burner is operating and a photocurrent is generated. Therefore an interruption of the burner operation due to a decrease in oil temperature is prevented (e.g. in case of high oil flow).
- According to EN 230 A2.1, the short circuiting of the thermo-switch is allowed only for an oil flow of max. 10 kg/h. Burners with a higher throughput have to shut down if the oil temperature gets below the allowed minimum. In such a case the thermo-switch has to be put in the phase-circuit and terminals 4 and 6 have to be connected with a link.

Without oil heater:

- In such a case the terminals 4 and 6 have to be connected with a link.

### 3. Low-voltage protection

TF 804.2 only

- The mains voltage has to be more than  $187 V_{\text{eff}}$  in order to allow the unit to perform a start-up.
- The mains voltage is not only monitored in the start-up phase but also permanently during operation. If the voltage drops below  $<160 V_{\text{eff}}$  during start-up or run time the control box goes into lockout mode. If the voltage rises again, the control box performs automatically a start-up as soon as the mains voltage is  $>187 V_{\text{eff}}$ .

### 4. Safety

The design and control sequence of the TF 804/TF 804.2 control boxes comply with the currently applicable European standards and regulations.

### 6. Mounting and electrical wiring

Wiring base:

- 3 earth terminals with additional terminal for burner earthing
- 3 neutral terminals with internal permanent connection to neutral terminal (terminal 7)
- 2 spare auxiliary terminals
- 2 slide in plates and 2 easy-knockout holes (PG 11 thread), plus 2 easy-knockout holes in the bottom of the base facilitate the wiring.
- The 3-wire sensor cable can be used for the IRD and UVD as well as for the FZ711 S. Please keep that in mind for burners which may be upgraded from FZ to IRD or UVD later on (e.g. upgraded to a blue flame burner).

General:

- The control box can be mounted in any position. The protection class is IP44 (water spray tight). Neither the control box nor the flame detector should be subjected to excessive vibration.

## COMMISSIONING AND ROUTINE CHECKS

### 1. Important notes

- The controls must be installed by qualified personnel only. The relevant national regulations have to be observed.
- On commissioning the wiring has to be carefully checked according the appropriate diagram, incorrect wiring can damage the unit and endanger the installation.
- The fuse rating has to ensure that the limits specified in TECHNICAL DATA will not be exceeded. If these precautions are not observed, the effect of a short circuit can cause severe damage to the control and installation.
- For safety reasons a minimum of one control shut-down per 24 hours has to be observed.
- Disconnect the mains before the control box is plugged in or out!
- The control box is a safety device and must not be opened!

### 2. Function control

For safety reasons the flame detection system should be tested on commissioning the installation as well as after a service or longer shut-down.

Condition: mains voltage  $>187 V_{\text{eff}}$  (for TF804.2 only)

- a) Start-up with covered flame detector
  - After lock-out safety time is over the unit has to go in to lockout mode!
- b) Start-up with exposed flame detector:
  - After 20 sec. pre-purge time the unit has to go into lockout mode!
- c) Normal start-up with burner in the normal position, cover up the flame detector:
  - After start-up, and end of lock-out safety time the unit has to go into lockout mode!
- d) The flame sensor signals can be checked either using the UP 940 or performing the following measurements:
  - For TF804 only: The measured sensor signal during operation should be minimal 2.4mA
  - For TF804.2 only: The sensor signal measurements are not reliable, as only marginal values changes occur. Measure instead the voltage across the photo resistor! For a reliable flame monitoring the DC voltage across the photo resistor (terminal 1 and 2) in operating mode should be less than 2 V.

### 3. Fault findings

Burner is not working:

- thermostat circuit open
- faulty electrical wiring
- mains voltage  $<187 V_{\text{eff}}$  (for TF804.2 only)

Burner starts, but the flame does not establish, a lock out occurs:

- stray light on flame detector
- no ignition or no fuel

Burner starts, the flame establishes, but after the safety time, a lock out occurs:

- dirty or faulty flame detector
- insufficient light on detector
- sensitivity adjustment too low on IRD.

For a quick and safe diagnosis use the Satronic UP 940 burner test box.

**CIRCUIT AND TIMING DIAGRAM TF 804/TF 804.2**

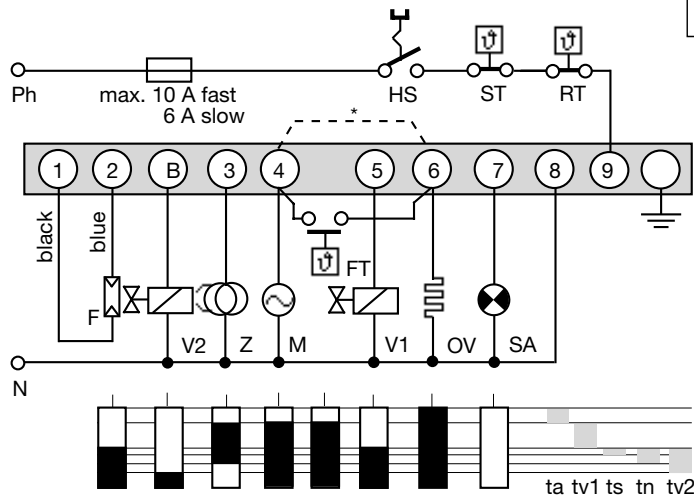

**IRD-OR UVD CONNECTION**

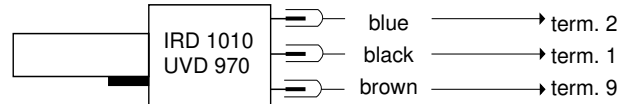

- HS Mains switch
- ST Limit thermostat
- RT Control thermostat
- F Flame detector FZ 711 S (IRD 1010, UVD 970 see separate diagram)
- Z Ignition
- M Burner motor (burner with solenoid valve)
- V1, V2 Solenoid valves
- OV Oil preheater
- FT Release thermostat
- SA External lock-out signal
- \* With burners without fuel heaters terminals 4 and 6 have to be connected with a jumper.
- ta Pre-heat-time
- tv1 Pre-ignition time with or without pre-purge
- ts Lock-out safety time
- tn Post-ignition time
- tv2 Delay 2nd stage

**SCHEMATIC DIAGRAM TF 804.2**

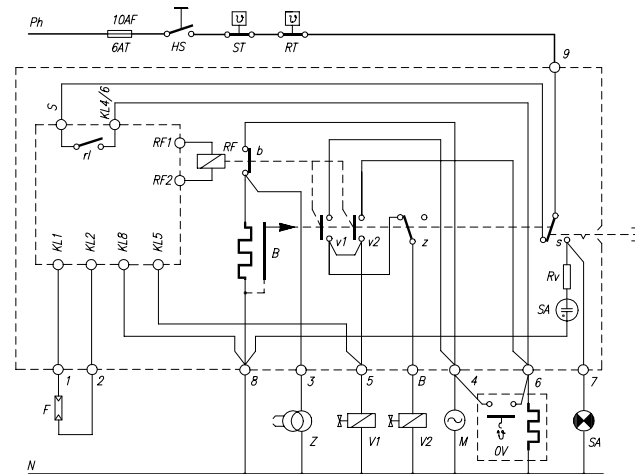

- HS Mains switch
- ST Limit thermostat
- RT Control thermostat
- SA Lock-out signal indicator
- F Flame detector MZ 770 S, IRD 1010 or UVD 970
- V Valves
- Z Ignition
- M Burner motor
- RF Flame relay
- r1 low voltage relay
- B Thermomechanical timer
- RV Resistor

### TF 804/804.2 AND SOCKET

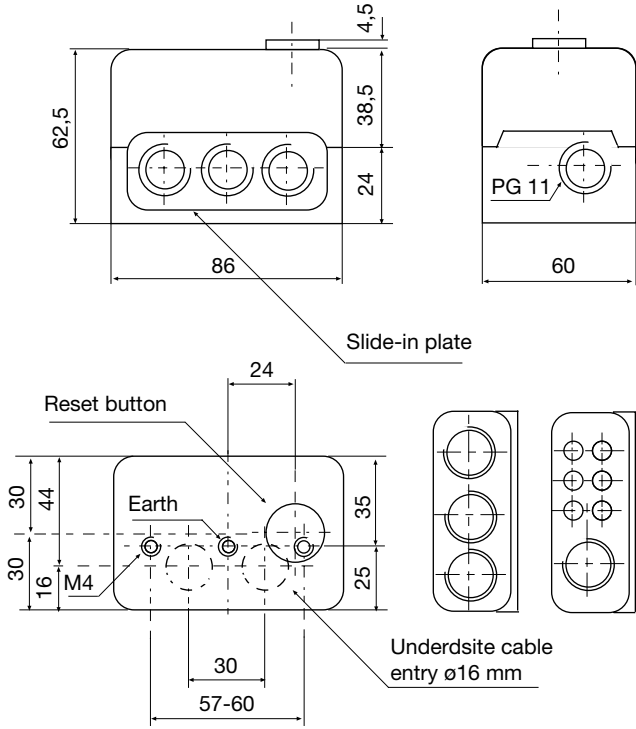

### PHOTORESISTOR FZ 711 S

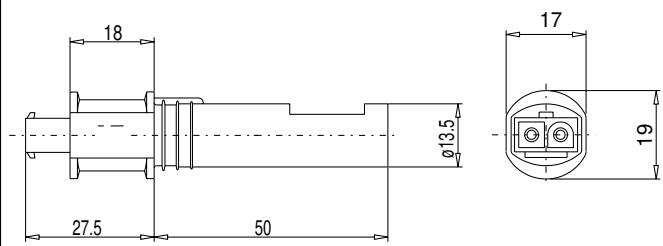

### HOLDER M74 FOR FZ, IRD OR UVD

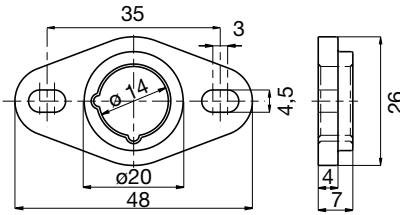

### UVD 970

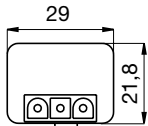

### IRD 1010

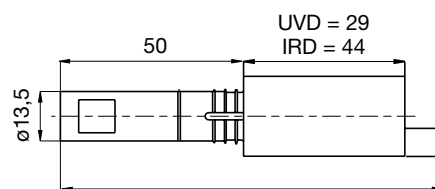
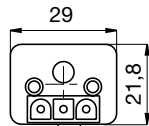

### VARIATION IRD

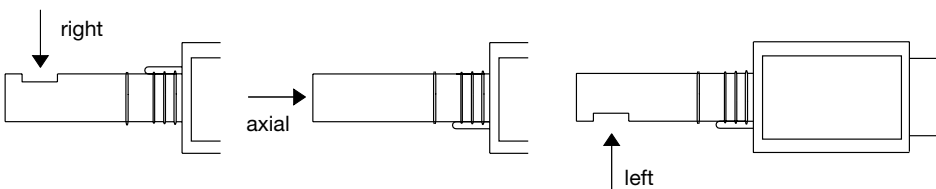

### ORDERING INFORMATION

ITEM	DESIGNATION	ITEM NO.
Control box	Type TF 804	02005
or	Type TF 804.2	02025
Socket	Socket 701 ABEN	70001
Insert plate	PG-Plate	70502
optional	Cable entry plate	70501
Flame detector	FZ 711 S red	40001
optional	FZ 711 S white	41001
optional	IRD 1010 right	16501
optional	IRD 1010 end-on	16502
optional	IRD 1010 left	16503
optional	UVD 970	16702
Support for flame detector	Holder M 74 for FZ, IRD, UVD	59074
Connectioncable IRD/FZ/UVD	Plug type, 3 core cable, 0.6 m, with tag wire ends	7236001
Connectioncable FZ 711 S	Plug type, 2 core cable, 0.5 m, with tag wire ends	7225001

The above ordering information refers to the standard version.

Special versions are also included in our product range.

Specifications subject to change without notice

# TF 804 / 804.2

**satronic**  
A Honeywell Company