

SIPHON TYPE SNA™ Air Atomizing Nozzles

for extremely fine spray
particle size at low air pressures



SPRAY CHARACTERISTICS

- Produces a solid cone spray pattern with extremely fine particle size at low air pressures and low CFM.
- Flow rates, spray angles and droplet sizes can be modified, with limitations, by variations in air, lift, etc.
- Clog free operation of low volume due to relatively large passages.

The nozzle will flow in either a horizontal or vertical position. The lift distance for a vertical mounted nozzle is measured from the liquid level to the end (face) of the nozzle. The lift distance for the horizontal mounting is shown in the installation drawing.

If the combustion application does not permit the use of a constant level device, excellent spray characteristics can be obtained using a fuel metering pump and an air compressor. It is also possible to operate the nozzle in a closed pressurized system utilizing air pressure for both lifting and atomizing the fuel.

INSTALLATION

The air compressor should be capable of providing at least 10% more air than the specified values. All fuel and air line connections must be tight. Any leaks, especially in the fuel line, will have an adverse effect on the lift characteristics.

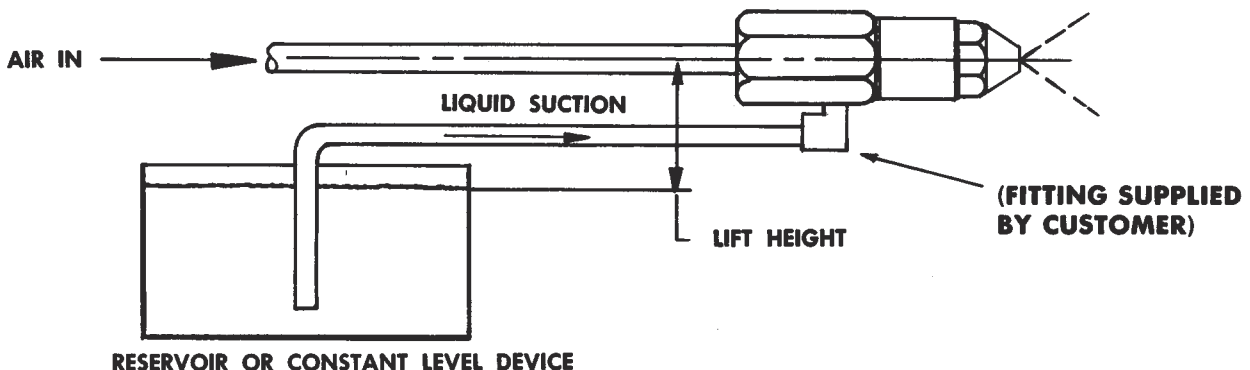

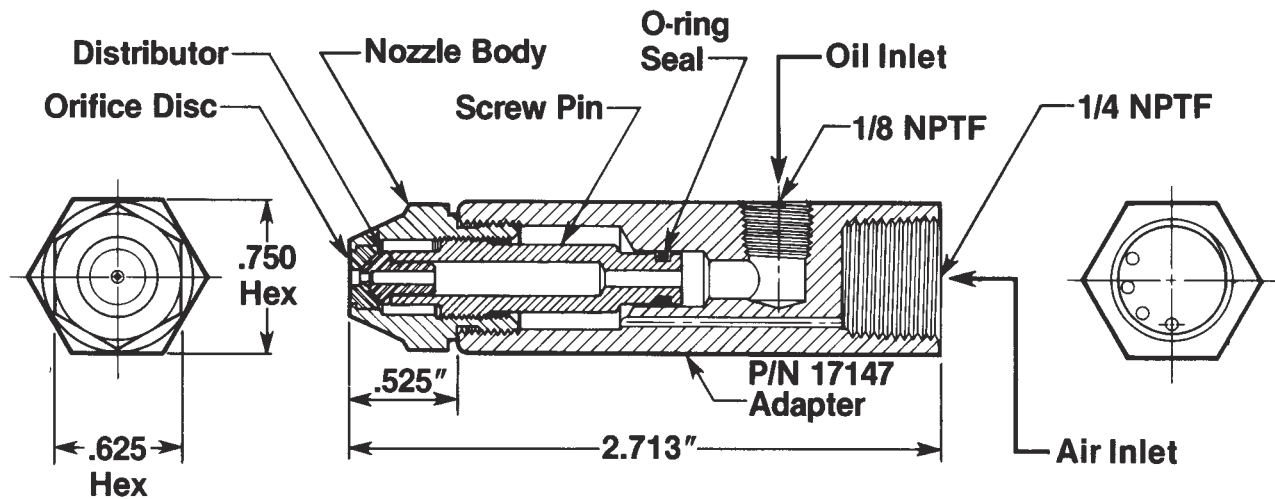

Siphon Type SNA Nozzle P/N 30609

Siphon Nozzle Capacity Chart

Part Number	Nozzle No.	3 PSIG Air		4 PSIG Air		5 PSIG Air		Lift Height (Inches)
		Fuel (GPH)	Air (CFM)	Fuel (GPH)	Air (CFM)	Fuel (GPH)	Air (CFM)	
30609-2	SNA .20	.19	.36	.23	.45	.25	.49	1
		.16	.36	.20	.45	.22	.49	4
		.14	.36	.17	.45	.20	.49	7
30609-3	SNA .30	.29	.41	.33	.49	.36	.55	1
		.26	.41	.30	.49	.33	.55	4
		.23	.41	.27	.49	.30	.55	7
30609-4	SNA .40	.38	.45	.44	.54	.49	.61	1
		.34	.45	.40	.54	.45	.61	4
		.30	.45	.36	.54	.41	.61	7
30609-5	SNA .50	.48	.50	.54	.59	.58	.65	1
		.43	.50	.50	.59	.53	.65	4
		.38	.50	.46	.59	.48	.65	7
30609-7	SNA .65	.63	.59	.72	.67	.78	.76	1
		.57	.59	.65	.67	.72	.76	4
		.51	.59	.58	.67	.66	.76	7
30609-8	SNA .75	.75	.63	.83	.74	.93	.87	1
		.65	.63	.75	.74	.84	.87	4
		.59	.63	.67	.74	.75	.87	7
30609-9	SNA .85	.84	.71	.93	.80	1.04	.93	1
		.75	.71	.85	.80	.95	.93	4
		.66	.71	.77	.80	.86	.93	7
30609-11	SNA 1.00	.96	.73	1.10	.91	1.15	1.02	1
		.84	.73	1.00	.91	1.06	1.02	4
		.72	.73	.90	.91	.97	1.02	7

ORDERING INSTRUCTIONS

WHEN ORDERING SIPHON TYPE SNA NOZZLES, be sure to include both part number and description. Specify P/N 30609 – (see nozzle capacity chart for dash number corresponding to flow and spray angle desired). Order adapter separately (specify P/N 17147).