



## Actuators for air and gas dampers

## SQN72... SQN73...

Electromotoric actuators for air dampers and control valves of oil and gas burners of small to medium heat capacity.

The SQN72/SQN73 and this data sheet are intended for original equipment manufacturers (OEMs) using the SQN72/SQN73 in or on their products.

### Use

The SQN72/SQN73 actuators are designed for positioning and driving air/gas dampers of oil burners, gas burners, and other ancillary equipment of small and medium heat capacity. They also offer load-dependent control of the amount of fuel and combustion air.

The controlling elements are controlled as follows depending on the current burner load:

- In connection with P, PI, or PID controllers, such as the RWF5
- Directly via the different types of burner controls, such as LAL, LOA, LME, LMO, LFL, LGK16
- In connection with 1- or 2-wire control or 3-position controllers

### Features

- Impact-proof and heat-resistant plastic housings
- Screw terminals for electrical connections
- Maintenance-free gear train, which can be disengaged
- Internal position indication
- Easy-to-adjust end and auxiliary switches for adjusting the switching points
- Integrated electronic circuits
- Protection type IP54
- Holding torque 0.7...1.3 Nm
- Running times 4...30
- Direction of rotation SQN72 Counterclockwise  
SQN73 Clockwise.

## Supplementary documentation

---

Product type	Documentation type	Documentation number
LAL	Data sheet	N7153
LFL	Data sheet	N7451
LFL1.148	Data sheet	N7454
LGK16	Data sheet	N7785
LME2	Data sheet	N7101
LME7	Data sheet	N7105
LMO2 LMO4 LMO39	Data sheet	N7130
LOA2 LOA3	Data sheet	N7118
LOK16	Data sheet	N7785
RWF50	Data sheet	N7866
	User manual	U7866
RWF55	Data sheet	N7867
	User manual	U7867



**To avoid personal injury or damage to property or the environment, the following warning notes must be observed.**

**Only qualified personnel may open, interfere with or modify the actuators!**

- Read the documentation on the actuators carefully and fully. If not observed, dangerous situations might occur
- The user must ensure that the actuators meet the requirements of the relevant application standards
- The control functions inside the actuator are not intended to ensure the safety of the overall application. Users must take this into account during the electrical integration of any systems (e.g., burner controls), and perform a risk analysis of the respective unit
- Safety-relevant applications are only available with Siemens burner controls. An application-specific risk analysis must still be carried out
- All product-related activities (mounting, settings, and maintenance) must be performed by appropriately qualified and authorized personnel
- Before making any wiring changes in the connection area, completely isolate the plant from the power supply (all-polar disconnection). Ensure that the plant cannot be inadvertently switched on again and that it is indeed dead. If the plant is not switched off, there is a risk of electric shock
- Take suitable measures to provide touch protection at the electrical connections and ensure the housing cover is screwed down tight
- Each time work has been carried out (mounting, installation, service work, etc.), check that the wiring is in an orderly state
- These units must not be put back into operation following impact or shock; even if they do not exhibit any visible damage, their safety functions may be impaired



**Please note!**

**Risk of electric shock hazard**

- **To disconnect the unit from power, it may be necessary to open more than one switch. Before performing maintenance work, the unit must be disconnected from power**
  - **All cam switch settings must satisfy the requirements of the relevant application standards**
- To ensure protection against electric shock, the connection terminals must have adequate touch protection. Make certain that non-insulated connections or wires cannot be touched. The housing cover must be screwed tight
  - Static charges must be avoided since they can damage the electronic components of the unit when touched.

**Recommendation:**

Use ESD equipment

## Selection of actuator version

---

- Ensure that any torque from outside acting on the controlling element (e.g., torque from the airflow produced by the burner fan) is smaller than the self-holding torque of the actuator in zero-current state
- The mechanical design of the burner must be such that any inadmissibly high torque from outside acting on the controlling element will not lead to critical burner operation.

Example:

If a torque acts on the asymmetrical bearing of the air damper due to the airflow in the air duct of the burner, the air damper is moved in the OPEN direction. This leads to a certain amount of excess air during combustion, which is less critical than a lack of air.

## Mounting notes

---

- Ensure that the relevant national safety regulations and notes on standards are complied with
- In the geographical areas where DIN regulations are in use for mounting and installation, the requirements of VDE must be complied with, especially DIN/VDE 0100, 0550, and DIN/VDE 0722
- Make certain that the actuator is not exposed to direct solar radiation
- The connection between the actuator shaft and controlling element must be **form-fitted** and **backlash-free**
- When mounting the actuator, be aware that additional axial and radial bearing loads are not permitted
- Be sure to observe the correct mounting sequence when mounting the actuator to the controlling element.

This is usually as follows:

1. Fit and secure the actuator
2. Connect the actuator shaft to the controlling element via a coupling pin

IP54

To ensure protection class IP54 throughout the lifetime of the actuator, the bearing of the actuator drive shaft must be located somewhere it will not be directly exposed to water or dust.

Form-fitted design



### Please note!

Possible shaft/hub connections:

- Flattened shaft with corresponding counterpart

To avoid inadmissible bearing loads caused by rigid hubs, it is recommended to use compensating couplings with no mechanical play (e.g., metal bellows couplings).

- When dimensioning a shaft connection, note that torques higher than the rated output torque of the actuator can also act during operation:
  - The actuator itself can apply a higher torque under optimum operating conditions
  - The effect of mass moments of inertia (caused by the rotating parts in the motor as well as on the actuator) can lead to sudden peak loads
- Siemens recommends overdimensioning the shaft connection by a factor of 2 compared to the rated torque of the actuator
- The connection between the actuator and burner or controlling element must be very rigid (no bending). This is particularly important when using column-mounted structures

## Installation notes

---

- Ensure that the electrical wiring is in compliance with national and local regulations
- Ensure that the strain relief of the connected cables is in compliance with the relevant standards (e.g., as per EN 60730 and EN 60335 series of standards)
- Ensure that spliced wires cannot come into contact with neighboring connections. Fit suitable ferrules
- When wiring the unit, the 230 V AC range must be strictly separated from the touchable low-voltage areas to ensure protection against electric shock
- The connection between the actuator shaft and the relevant controlling element must be form-fitted
- Only plastic versions of cable glands may be used

## Standards and certificates

---



### Applied directives:

- Low Voltage Directive 2014/35/EU
- Electromagnetic compatibility EMC (immunity) 2014/30/EU

Compliance with the regulations of the applied directives is verified by the adherence to the following standards/regulations:

- Automatic electrical controls for household and similar use DIN EN 60730-1  
Part 1:  
General requirements
- Automatic electrical controls for household and similar use DIN EN IEC 60730-2-14  
Part 2-14:  
Particular requirements for electric actuators

**The relevant valid edition of the standards can be found in the declaration of conformity.**



EAC conformity (Eurasian compliance)



UKCA conformity mark (UK compliance)



China RoHS  
Hazardous substances table:  
<http://www.siemens.com/download?A6V10883536>

## Lifetime

---

The actuator has a designed lifetime\* of 250,000 burner startup cycles (OFF ⇒ ON ⇒ OFF) under load with the rated torque in the entire rotation angle range, which under normal operating conditions in heating mode corresponds to approx. 10 years of service (starting from the production date given on the type label). This is based on the endurance tests specified in the EN 298 standard. A summary of the conditions has been published by the European Control Manufacturers Association (Afecon) ([www.afecor.org](http://www.afecor.org)).

The designed lifetime is based on use of the actuator according to the manufacturer's data sheet. After reaching the designed lifetime in terms of the number of burner startup cycles, or after the corresponding usage time, the actuator must be replaced by authorized personnel.

\*The designed lifetime is not the warranty time specified in the terms of delivery

## Service notes

---

Unit replacement	<p>When replacing an actuator, the following points must be checked and corrected if necessary:</p> <ul style="list-style-type: none"><li>• Correct connection to the basic unit</li><li>• Assignment of functions</li></ul>
------------------	--

## Disposal notes

---

The SQN72/SQN73 contains electrical and electronic components and must not be disposed of together with domestic waste. Local and currently valid legislation must be observed.

## Design

---

Housing	<ul style="list-style-type: none"><li>• The lower housing is made of dark gray, impact-proof and heat-resistant plastic</li><li>• The housing cover is made of light gray, impact-proof and heat-resistant plastic</li><li>• The housing accommodates:<ul style="list-style-type: none"><li>– the synchronous motor with the disengageable reduction gear train</li><li>– the camshaft of the control section</li><li>– the relays – depending on the type</li><li>– the switch section – connected to the plug-in spaces of the connection terminals via an assembled PCB</li></ul></li></ul>
Actuator motor	Synchronous motor.
Coupling	<ul style="list-style-type: none"><li>• Shaft can be disengaged from the gear train and motor by manually actuating the coupling (pressure pin (K))</li><li>• Automatic reset</li></ul>

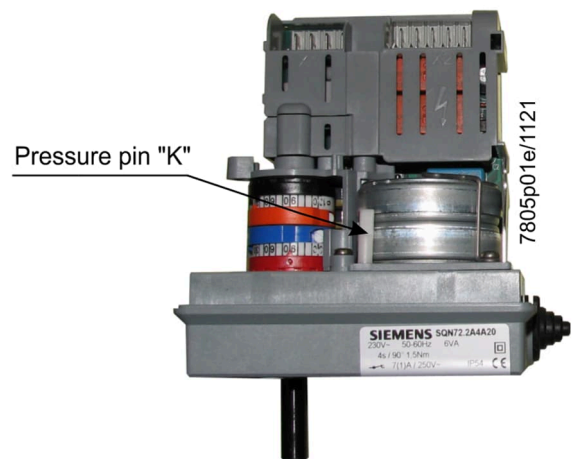

Switching point adjustment	<ul style="list-style-type: none"><li>• Via rotating cam disks</li><li>• Scales adjacent to the cams indicate the angle of the switching point</li><li>• Cam disks with fine adjustment, adjustable with standard screwdriver</li><li>• Assignment of the cam disks to the color-coded end switches and auxiliary switches, refer to <i>Circuit diagrams</i></li></ul>
Position display	Internal: Scale at the beginning of the camshaft on the gear train side.
Connection technology	Refer to <i>Technical data</i> .
Gear train	Maintenance free.
Drive shaft	<ul style="list-style-type: none"><li>• Burnished steel</li><li>• Fixed on one side on the front of the gear train</li><li>• Available as an actuator variant in different versions</li></ul>
Mounting and fastening	<ul style="list-style-type: none"><li>• Front of gear train as a bearing surface</li><li>• Fastening with through holes</li></ul>

### Special versions for potentiometer installation

---

Potentiometer installation	Certain types of actuators are supplied ready prepared for installing a potentiometer. They are manufactured to accommodate the potentiometer and do not require any further parts.
Conversion by the user	Users have the choice of converting a basic type of actuator to a version for installing a potentiometer. If a potentiometer is required, it must always be ordered separately, refer to <i>Accessories</i> .

## Type summary (further types on request)

### SQN72 actuators / direction of rotation <sup>5)</sup> counterclockwise

Diagram no.	Shaft <sup>1)</sup> no.	Running time at 50 Hz <sup>2)</sup> for 90° (s)	Nominal torque (max.) Nm	Holding torque Nm	Auxiliary switch <sup>4)</sup> Unit	Relay Unit	Potentiometer <sup>6)</sup>	Housing length <sup>1)</sup> mm	Types for mains voltage / mains frequency	
									230 V AC <sup>3)</sup> +10%/-15% 50...60 Hz	
									Article no.	Type
B	1	4	1.5	0.7	2	3	---	117	<b>S55454-D303-A100</b>	<b>SQN72.2B4A21</b>
B	1	4	1.5	0.7	2	3	---	117	<b>S55454-D351-A100</b>	<b>SQN72.2B4B21</b>
C	0	4	1.5	0.7	2	---	●	117	<b>BPZ:SQN72.2C4A20 <sup>7)</sup></b>	<b>SQN72.2C4A20 <sup>7)</sup></b>
C	1	12	2.5	1.2	2	---	●	117	<b>S55454-D301-A100</b>	<b>SQN72.4C4A21</b>
D	0	12	2.5	1.2	3	2	---	117	<b>BPZ:SQN72.4D5B20</b>	<b>SQN72.4D5B20 <sup>7)</sup></b>
C	0	30	2.5	1.3	2	---	●	117	<b>BPZ:SQN72.6C4A20</b>	<b>SQN72.6C4A20</b>
C	1	30	2.5	1.3	2	---	●	117	<b>BPZ:SQN72.6C4A21</b>	<b>SQN72.6C4A21</b>
E	0	30	2.5	1.3	3	---	---	117	<b>BPZ:SQN72.6E5A20</b>	<b>SQN72.6E5A20 <sup>7)</sup></b>

#### Key

- 1) Refer to *Dimensions*
- 2) Specifications apply to 50 Hz; at 60 Hz, the running times are about 17% shorter.
- 3) Approx. 20% torque reduction with undervoltage
- 4) Free auxiliary switches (along with 2 end switches)
- 5) When looking at the shaft and control voltage at end switch I
- 6) Directly suitable for potentiometer installation, refer to chapter *Potentiometer installation*
- 7) On request

### SQN73 actuators / direction of rotation <sup>5)</sup> clockwise

Diagram no.	Shaft <sup>1)</sup> no.	Running time at 50 Hz <sup>2)</sup> for 90° (s)	Nominal torque (max.) Nm	Holding torque Nm	Auxiliary switch <sup>4)</sup> Unit	Relay Unit	Potentiometer <sup>5)</sup>	Housing length <sup>1)</sup> mm	Types for mains voltage / mains frequency	
									230 V AC <sup>3)</sup> +10%/-15% 50...60 Hz	
									Article no.	Type
B	0	4	1.5	0.7	2	3	---	117	<b>S55454-D355-A100</b>	<b>SQN73.2B4A20</b>
B	0	4	1.5	0.7	2	3	---	117	<b>S55454-D354-A100</b>	<b>SQN73.2B4B20</b>
C	0	4	1.5	0.7	2	---	●	117	<b>S55454-D353-A100</b>	<b>SQN73.2C4A20</b>
B	0	12	2.5	1.2	2	3	---	117	<b>S55454-D352-A100</b>	<b>SQN73.4B4B20</b>

#### Key

- 1) Refer to *Dimensions*
- 2) Specifications apply to 50 Hz; at 60 Hz, the running times are about 17% shorter.
- 3) Approx. 20% torque reduction with undervoltage
- 4) Free auxiliary switches (along with 2 end switches)
- 5) Directly suitable for potentiometer installation, refer to chapter *Potentiometer installation*



Type summary (further types on request)

---

Torque at rated voltage

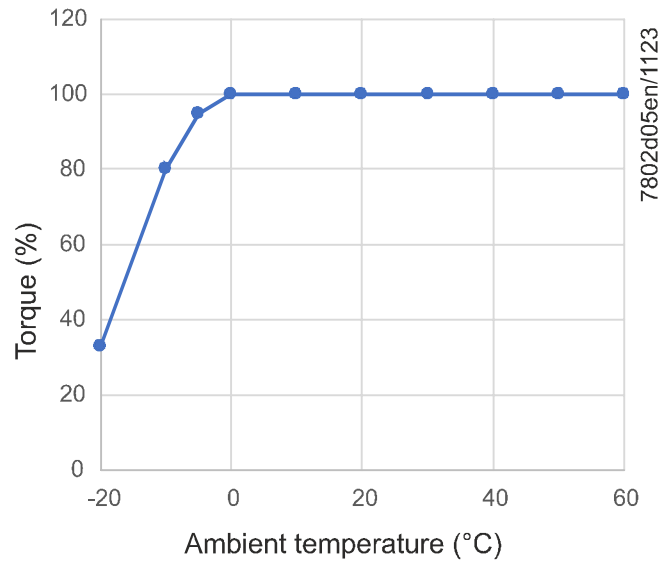

## Accessories (must be ordered separately)

---

Proportional controlling element with mounting plate **VKP**  
Proportional controlling element for mounting between threaded flanges in gas trains.  
Refer to Data Sheet N7646.



---

Example:

**ASZ** potentiometer  
Refer to Data Sheet N7921.



---

**RWF50** compact universal controller  
For load-dependent control of the amount of fuel and combustion air in connection with P, PI, or PID controllers.  
Refer to Data Sheet N7866.



---

**RWF55** compact universal controller  
For load-dependent control of the amount of fuel and combustion air in connection with P, PI, or PID controllers.  
Refer to Data Sheet N7867.



## Technical data

### General unit data

#### Actuator

Mains voltage	230 V AC -15%/+10%
Mains frequency	50...60 Hz $\pm 6\%$
Actuator motor	Synchronous motor
Internal consumption	Max. 6 VA
External overload fuse	Max. 6.3 AT (slow) according to DIN EN 60127-5
Internal overload fuse	2 AT (slow), depending on the type, not interchangeable
Positioning angle, usable range	Max. 160°, scale range 0...130°
Mounting position	Optional
Degree of protection	IP54 in accordance with EN 60529:1991 + A1:2000 + A2:2013 when using the cable entry provided plus plastic washers for the <b>M</b> fixing screws as shown in the <i>Dimensions</i> chapter.





#### Please note!

**The drive shaft bearing must be installed appropriately to protect against direct exposure to water and dust, otherwise IP54 cannot be guaranteed for the entire lifetime.**

Protection class	II according to EN 60730-1:2016 + A1:2019 and EN IEC 60730-2-14:2019
Mode of operation	Type I, rotary motion / multi-position mode of operation
Cable entry	Rubber grommet for the insertion of a single sheathed cable with a maximum diameter of 11 mm. The opening of the rubber grommet must be suitably adapted to the sheath diameter of the cable. To ensure that the rubber grommet will be tight, the cable must be correctly laid in this area with no openings. The rubber grommet is included in the scope of delivery.
Cable strain relief	Cable strain relief bridge with 2 fixing screws included in scope of delivery

## Technical data (continued)

General unit data	Cable connection	2 plug-in spaces with connection terminals Type CUM / manufactured by Stelvio Kontek
		For the following connector types <sup>1)</sup> : <ul style="list-style-type: none"> <li>• CUF 5-3 (plug-in space X3) <sup>2)</sup></li> <li>• CUF 5-4 (plug-in space X1)</li> <li>• CUF 5-5 (plug-in space X2)</li> </ul>
		Recommended cross-sectional area of stranded wire Min. 0.5 mm <sup>2</sup> and max. 1.5 mm <sup>2</sup>
		<sup>1)</sup> Note! The connectors are not included in the scope of delivery (order directly from Stelvio Kontek).
		<sup>2)</sup> Note! Only available with circuits D and E.
	Ferrules	Matching the cross-sectional area of the stranded wire
	<u>Direction of rotation (when facing the shaft)</u>	
	SQN72	Counterclockwise
	SQN73	Clockwise
	Torque and holding torque	Refer to <i>Type summary</i>
	Running times	Refer to <i>Type summary</i>
	Pause time at change in direction of rotation	> 100 ms
	Lifetime	250,000 start cycles (OFF ⇌ ON ⇌ OFF) under load with the rated torque in the entire rotation angle range
	Weight (on average)	Approx. 500 g
	Temperature of the mounting surface	Max. 60°C
	Rated surge voltage	4 kV Overvoltage category III according to DIN EN 60730-1 (VDE 0631-1):2021-06, Section 20 Pollution degree 2
	Permissible on time	60%, maximum 3 minutes without interruption
	Additional restrictions for SQN7x.4xx, SQN7x.6xx	50%, ambient temperature from 24...35°C 40%, ambient temperature from 35...45°C 25%, ambient temperature from 45...60°C
	<u>Gear train backlash between the actuator motor and actuator shaft</u>	
	• Ex works	≤1.2° ±0.3°
	• After 250,000 cycles	≤1.5° ±0.3°

## Technical data (continued)

### End switches and auxiliary switches

Type	In accordance with DIN 41636-1
Switching voltage	24...250 V AC
Number of end switches	2
Number of auxiliary switches	Refer to <i>Type summary</i>
Actuation	Via camshaft, color-coded cam disks, refer to <i>Circuit diagrams</i> . Switches with fine adjustment
Engagement of the cam disks with fine adjustment	Infinitely variable
Maximum permissible current load at $\cos \varphi = 0.9$ : (Values in brackets: short-time peaks for max. 0.5 s)	



#### Please note!

**The control of fuel valves is only permitted at the cam designated for this purpose. When connecting a fuel valve: Max. 0.3 A,  $\cos \varphi > 0.8$  inductive. Safety-relevant applications are only available with Siemens burner controls!**

<ul style="list-style-type: none"> <li>• Connection diagram <b>A</b> <ul style="list-style-type: none"> <li>- Terminals 1, 2, 3, 8</li> </ul> </li> </ul>	<ul style="list-style-type: none"> <li>Max. 0.5 A</li> </ul>
<ul style="list-style-type: none"> <li>- Terminal 4, 5</li> <li>- Terminal 6, 7</li> </ul>	<ul style="list-style-type: none"> <li>Max. 2 A (5 A)</li> <li>Max. 1 A (5 A)</li> </ul>
<ul style="list-style-type: none"> <li>• Connection diagram <b>B</b> <ul style="list-style-type: none"> <li>- Terminals 1, 2, 3, 8</li> </ul> </li> </ul>	<ul style="list-style-type: none"> <li>Max. 0.5 A</li> </ul>
<ul style="list-style-type: none"> <li>- Terminal 4, 5</li> <li>- Terminal 6, 7</li> </ul>	<ul style="list-style-type: none"> <li>Max. 2 A (5 A)</li> <li>Max. 1 A (5 A)</li> </ul>
<ul style="list-style-type: none"> <li>• Connection diagram <b>C</b> <ul style="list-style-type: none"> <li>- Terminals 1, 2, 3, 4, 5</li> </ul> </li> </ul>	<ul style="list-style-type: none"> <li>Max. 0.5 A</li> </ul>
<ul style="list-style-type: none"> <li>- Terminals 6, 7, 8</li> </ul>	<ul style="list-style-type: none"> <li>Max. 1 A (5 A)</li> </ul>
<ul style="list-style-type: none"> <li>• Connection diagram <b>D</b> <ul style="list-style-type: none"> <li>- Terminals 1, 2, 3, 8</li> </ul> </li> </ul>	<ul style="list-style-type: none"> <li>Max. 0.5 A</li> </ul>
<ul style="list-style-type: none"> <li>- Terminal 4, 5</li> <li>- Terminal 6, 7, 9, 10, 11</li> </ul>	<ul style="list-style-type: none"> <li>Max. 2 A (5 A)</li> <li>Max. 1 A (5 A)</li> </ul>
<ul style="list-style-type: none"> <li>• Connection diagram <b>E</b> <ul style="list-style-type: none"> <li>- Terminals 1, 2, 3, 4, 5</li> </ul> </li> </ul>	<ul style="list-style-type: none"> <li>Max. 0.5 A</li> </ul>
<ul style="list-style-type: none"> <li>- Terminal 6, 7, 8, 9, 10, 11</li> </ul>	<ul style="list-style-type: none"> <li>Max. 1 A (5 A)</li> </ul>

## Technical data (continued)

---

### Environmental conditions

<b>Storage</b>	DIN EN 60721-3- 1: 1997
Climatic conditions	Class 1K3
Mechanical conditions	Class 1M2
Temperature range	-20...+60°C
Humidity	< 95% r.h.
<b>Transport</b>	DIN EN 60721-3- 2: 1997
Climatic conditions	Class 2K2
Mechanical conditions	Class 2M2
Temperature range	-50...+60°C
Humidity	< 95% r.h.
<b>Operation</b>	DIN EN 60721-3- 3: 1995
Climatic conditions	Class 3K5
Mechanical conditions	Class 3M2
Temperature range	-20...+60°C
Humidity	< 95% r.h.
Installation altitude	Max. 2,000 m above sea level

---



**Please note!**

**Condensation, formation of ice, and ingress of water are not permitted. Failure to observe this poses a risk of impairing the safety functions and the risk of electric shock.**

## Function

---

A synchronous motor drives the drive shaft with a mounted camshaft via a gear train. The camshaft actuates end switches and auxiliary switches. The switch position of each end switch and auxiliary switch can be adjusted by an assigned cams disk within the running range. Some actuator versions are equipped with electronic switching modules that perform additional functions in connection with the end switches and auxiliary switches and external units, such as controllers (refer to *Circuit diagrams*).

## Internal diagram (examples)



### Please note!

The following internal diagrams all show the start position as supplied:

- End switch position II CLOSED
- No voltage

**No. A** → 2-stage or modulating operation → Prepurging at high-fire position (NL)

e.g., for LME22

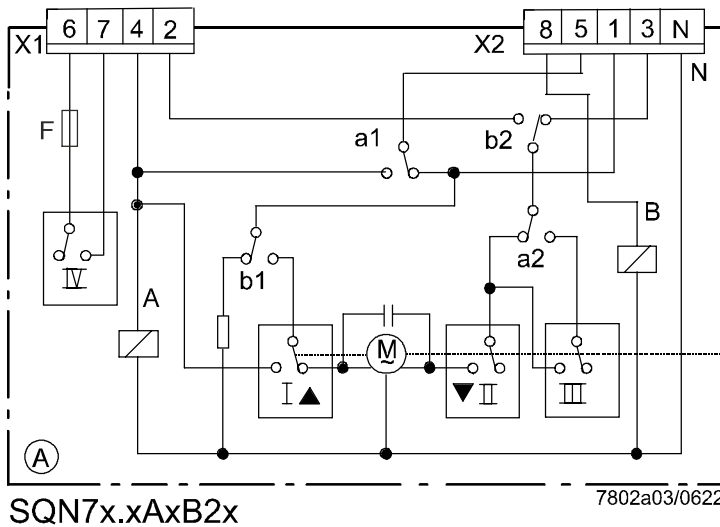

X1 Plug-in space, 4-pole  
X2 Plug-in space, 5-pole

Cam disks:  
I Red  
II Blue  
III Orange  
IV \*) Black



### Please note!

\*) Connection of a fuel valve to cam IV only:

→ Max. 0.3 A,  $\cos\phi > 0.8$  inductive.

Safety-relevant applications are only available with Siemens burner controls!

**No. B** → 2-stage operation → Prepurging at low-fire position (KL)

e.g., for LOA24 / LOA25 / LOA26 / LOA28 / LOA36 / LMO24 / LMO39 / LMO44

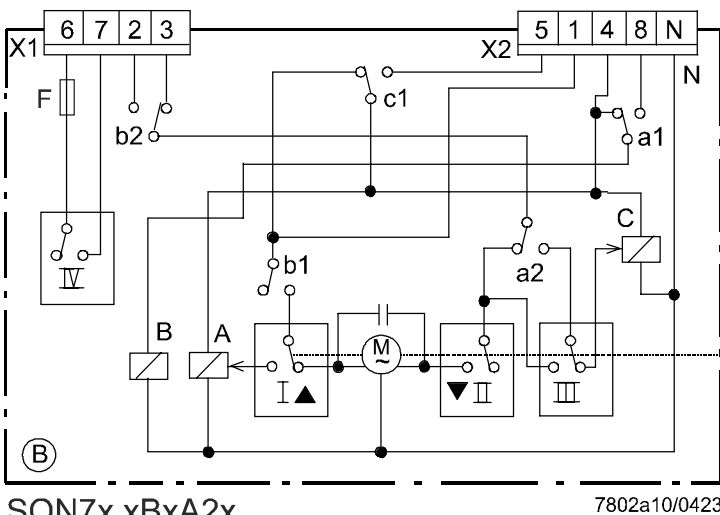

X1 Plug-in space, 4-pole  
X2 Plug-in space, 5-pole

Cam disks:  
I Red  
II Blue  
III Orange  
IV \*) Black



### Please note!

\*) Connection of a fuel valve to cam IV only:

→ Max. 0.3 A,  $\cos\phi > 0.8$  inductive.

Safety-relevant applications are only available with Siemens burner controls!

Internal diagram (examples) (continued)

**No. C → 2-stage or modulating operation → Prepurging at high-fire position (NL)  
e.g., for LFL / LGK16 / LAL / LOK16**

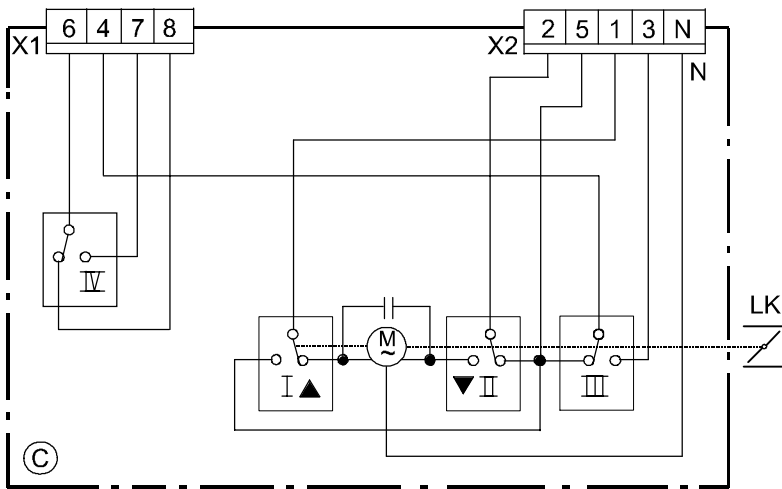

- X1 Plug-in space, 4-pole
- X2 Plug-in space, 5-pole

- Cam disks:
- I Red
  - II Blue
  - III Orange
  - IV Black

SQN7x.xCxA2x

7802a05/1121



**Please note!**  
The SQN7x.CxA2s in series A are not suitable for controlling the fuel valves according to the standard. Safety-relevant applications are only available with Siemens burner controls.

**No. D → 2-stage or modulating operation → Prepurging at high-fire position (NL)  
e.g., for LME22**

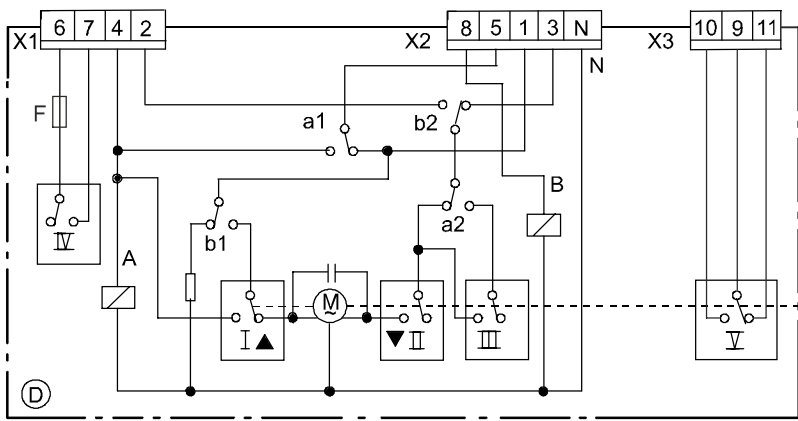

- X1 Plug-in space, 4-pole
- X2 Plug-in space, 5-pole
- X3 Plug-in space, 3-pole

- Cam disks:
- I Red
  - II Blue
  - III Orange
  - IV \*) Black
  - V Green

SQN7x.xDxB2x

7802a06/0423



\*)

**Please note!**  
Connection of a fuel valve to cam IV only:  
→ Max. 0.3 A,  $\cos\phi > 0.8$  inductive.  
Safety-relevant applications are only available with Siemens burner controls!



Internal diagram (examples) (continued)

No. E → 2-stage or modulating operation → Prepurging at high-fire position (NL)  
 e.g., for LAL / LFL / LGK16 / LOK16

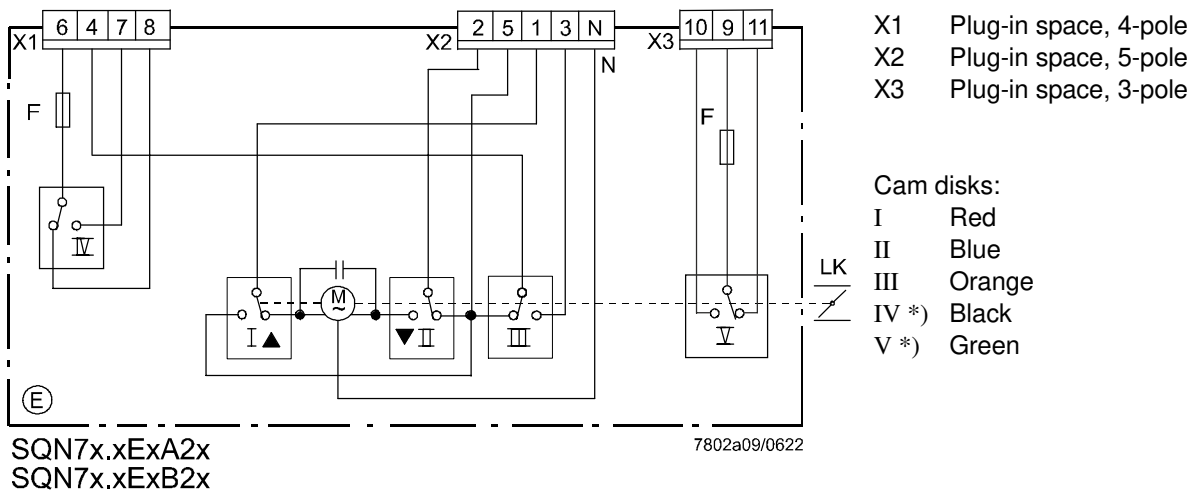





\*)

**Please note!**



**Connection of a fuel valve to cam IV or V only:  
 → Max. 0.3 A,  $\cos\phi > 0.8$  inductive.**

**Safety-relevant applications are only available with Siemens burner controls!**

No. A	Designation for internal circuit. Appears in the second position after the period in the type reference
I / II	End switches
III / IV / V	Auxiliary switches
AL	Remote lockout display (alarm)
BV1	Fuel valve stage 1
BV2	Fuel valve stage 2
BV3	Fuel valve stage 3
EK2	External remote lockout reset button
ION	Ionization probe
	Internal fuse, not replaceable
FS	Flame signal
GP	Gas pressure switch
HS	Main switch
KL	Low-fire
L	Phase
LK	Air damper
LKP	Air damper position
LP	Air pressure switch
LR	Load controller
M	Burner motor or fan motor
	Actuator synchronous motor
M1	Without postpurging
M2	With postpurging
N	Neutral conductor
NL	High-fire
OH	Oil preheater
OW	Oil preheater readiness contact
QRB	Photoresistive detector
R	Control thermostat or pressurestat
	Relay
RV	Control valve
SA	Actuator
Si	External primary fuse, as specified in the data sheet of the relevant burner control
SB	Safety limiter
STx	Stage
tx / Tx	Program times (refer to the data sheet of the relevant burner control)
TSA	Safety time
	Resistor
Z	Ignition transformer
CLOSED	Damper closed
▲	Direction of rotation OPEN
▼	Direction of rotation CLOSED

**Program sequence – Diagrams**

A	Burner ON
A–B	Burner startup
B–C	Burner operation / load control operation, modulating or 2-stage
C	Burner OFF
C–D	Overrun time
D	End of program sequence, burner control ready for restart

	Control signals delivered by burner control
	Required input signals
	Permissible input signals

# Dimensions

Dimensions in mm

SQN72 / SQN73

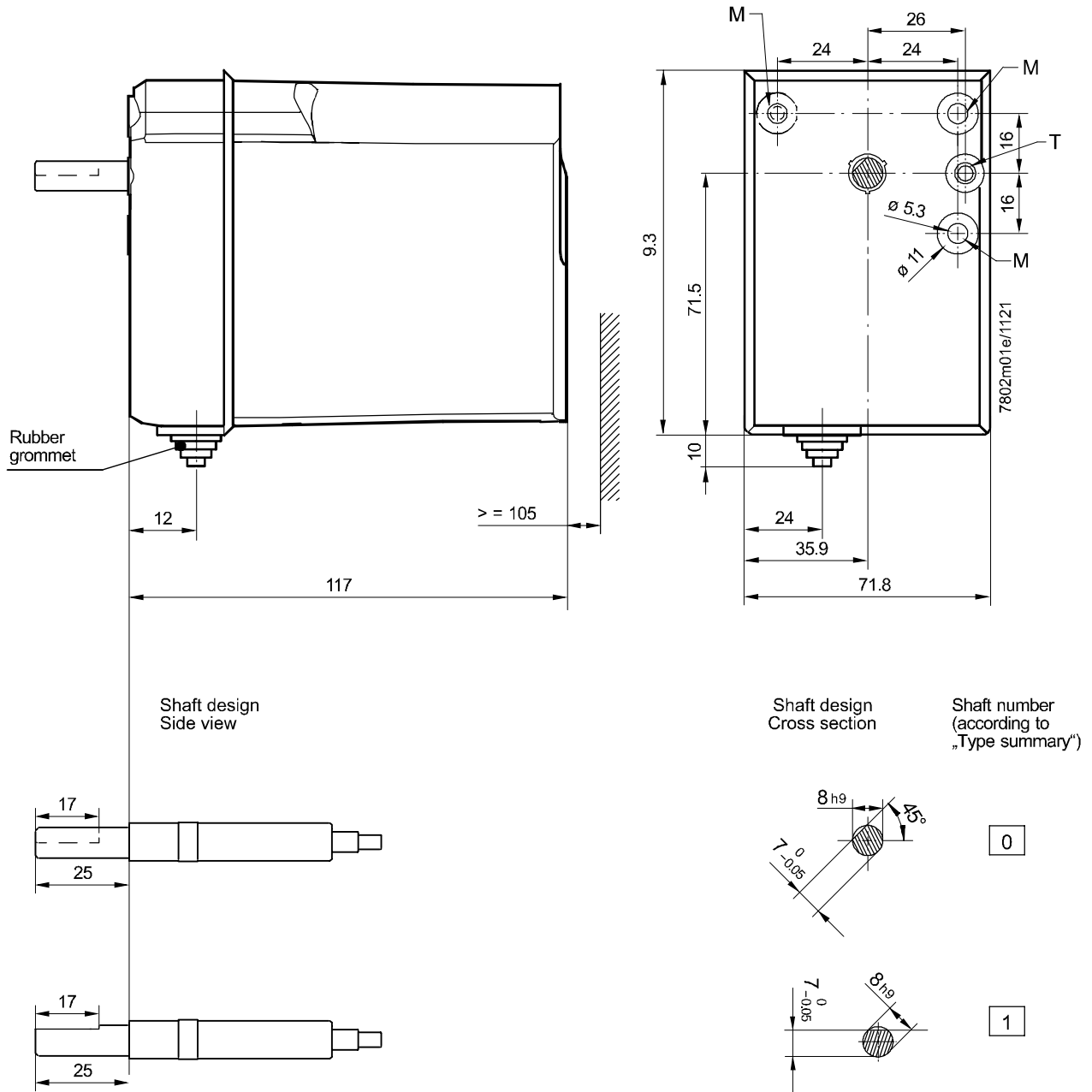

All shafts are shown in end switch position II CLOSED (as supplied).

- M Through-hole  $\phi 5.3$  mm
- T Knockout opening  $\phi 5.3$  mm



**Please note!**  
**Electric shock hazard**  
**The ASZ potentiometer must be installed when the unit is shut down.**

ASZxx.3x potentiometer

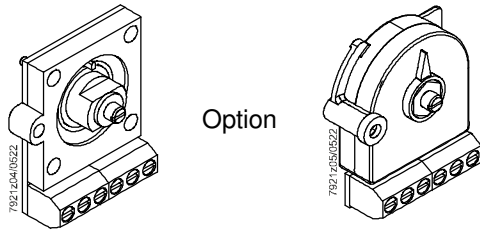

SQN7x actuators

SQN72.2C4x20  
 SQN72.4C4x21  
 SQN72.6C4x20  
 SQN72.6C4x21

SQN73.4B4x20

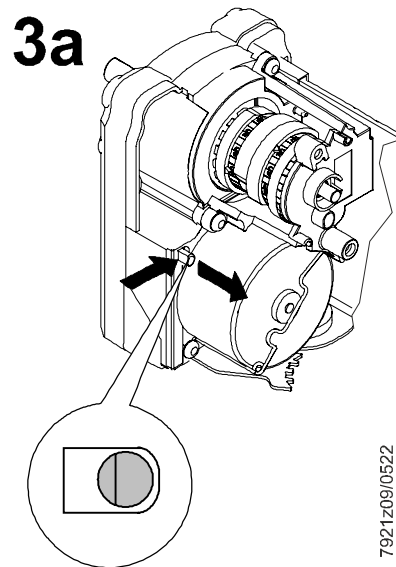
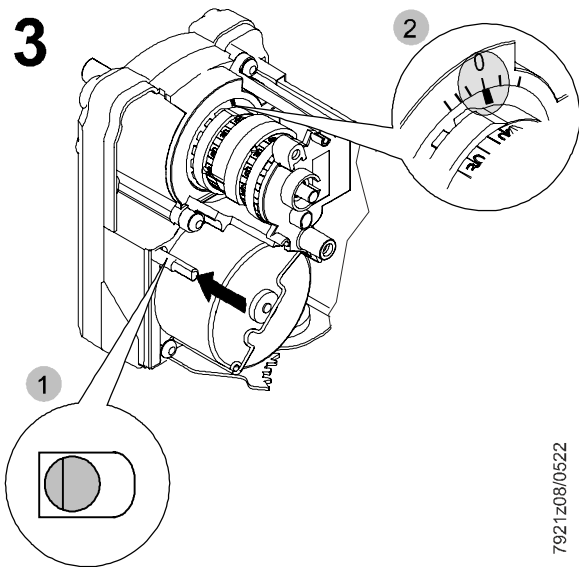
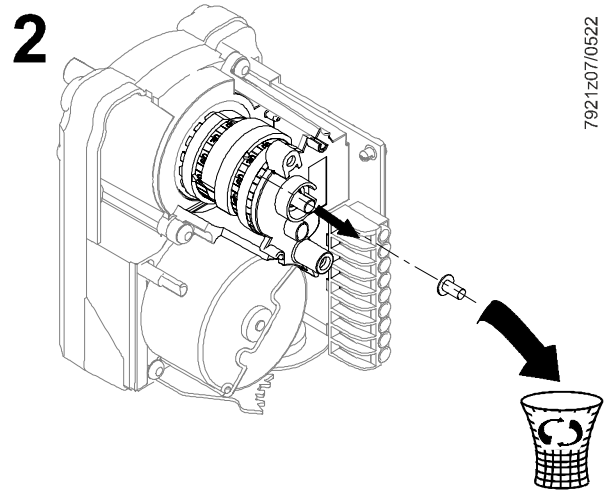
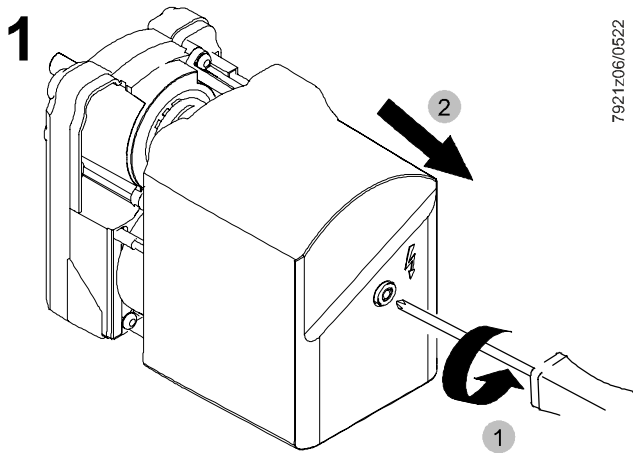

Installing the ASZxx.3x (continued)

4

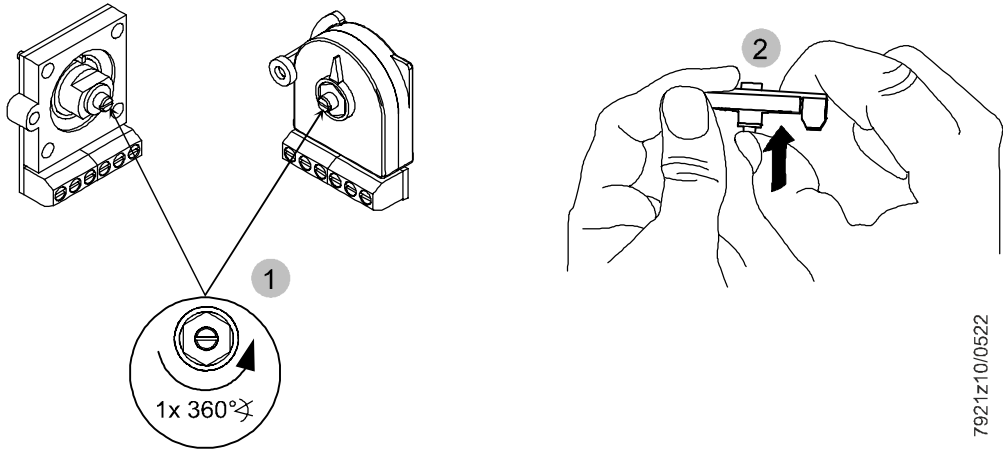

7921z10/0522

5

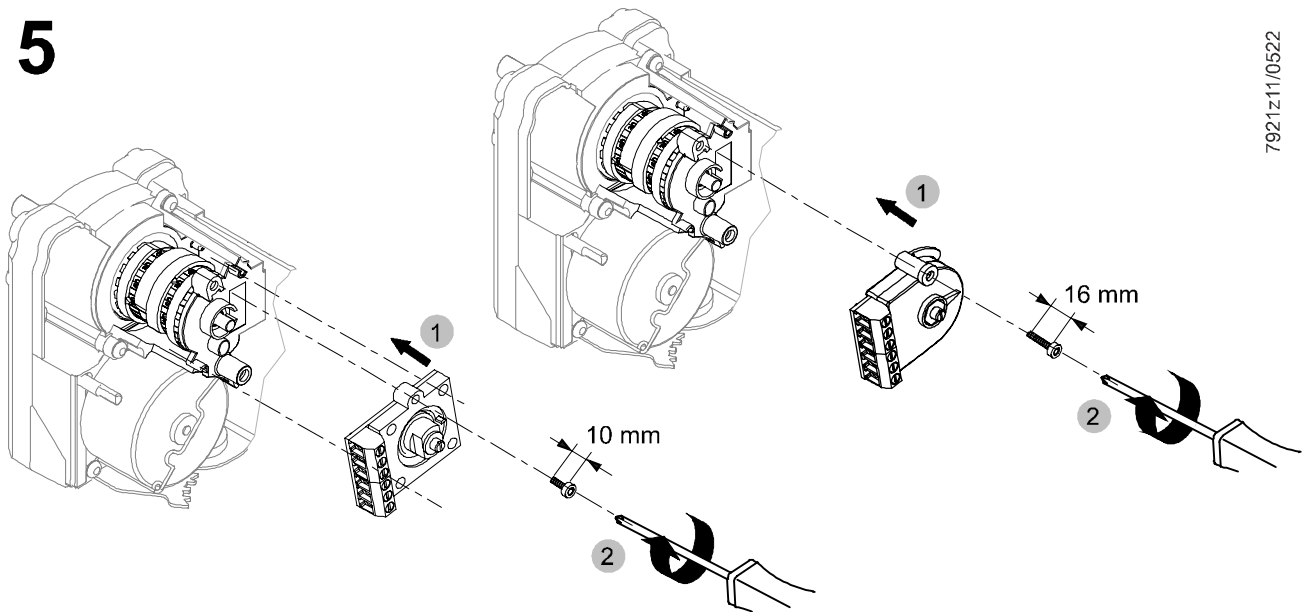

7921z11/0522

6

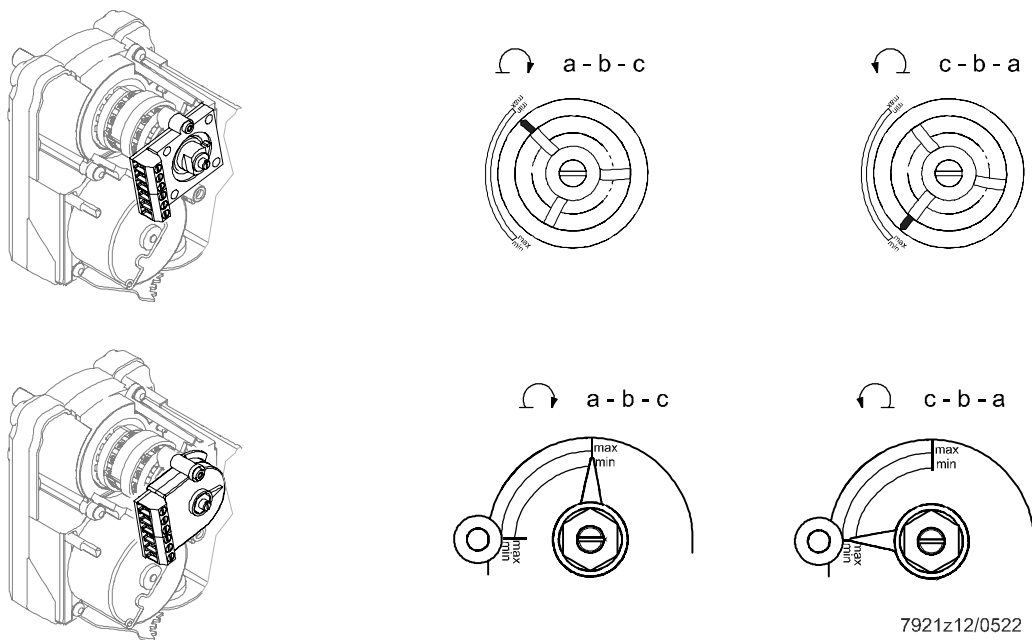

7921z12/0522

7

7921z13/0522

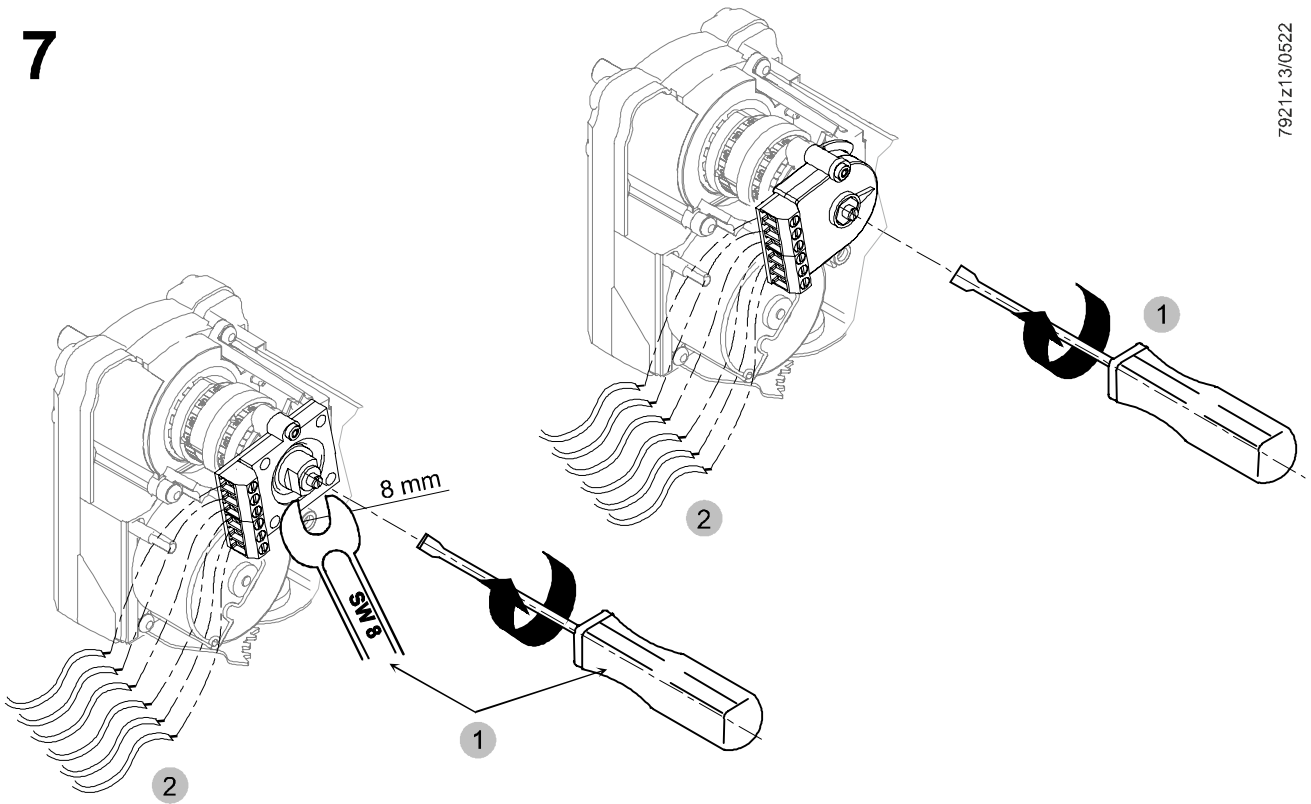

8

7921z15/0522

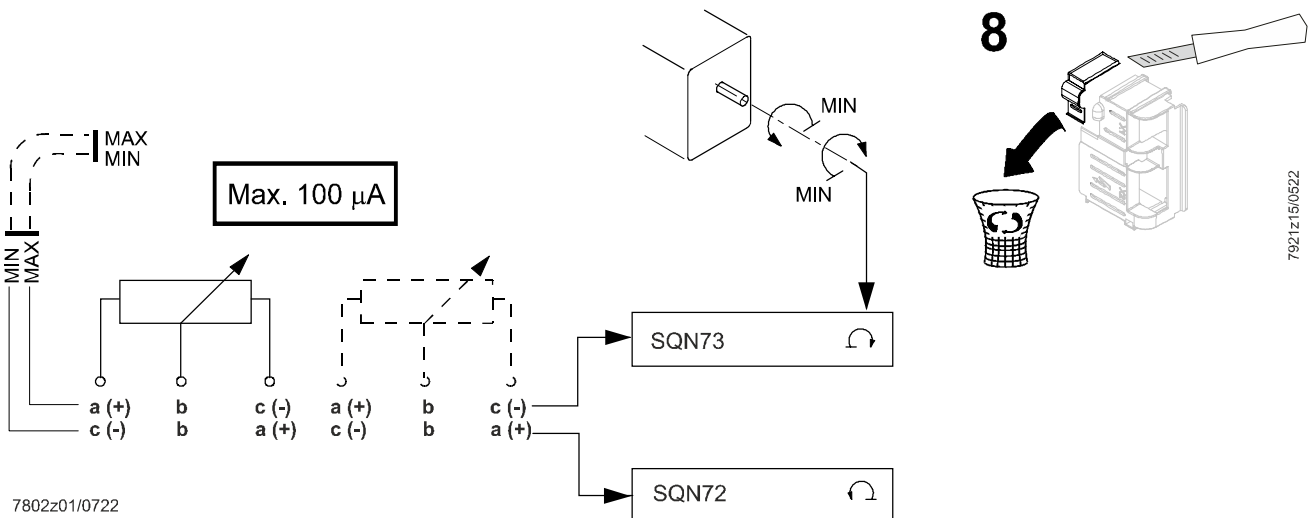

7802z01/0722

9

- 1 Put on the housing cover
- 2 Secure the housing cover

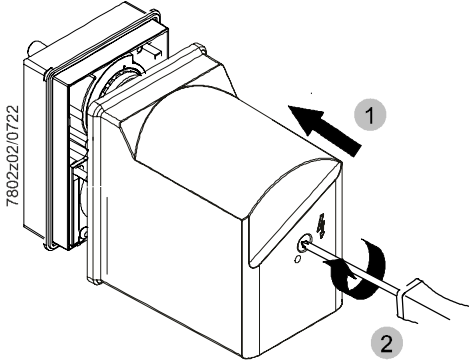

## Fitting the SQN72/SQN73 onto the VKF1x butterfly valve

### VKF10/VKF11

VKF10/VKF11  
contents

7673z05/1021

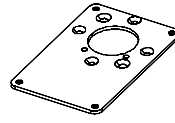
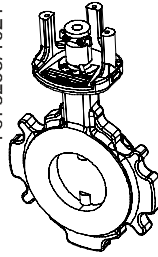

M5x12



M5x16

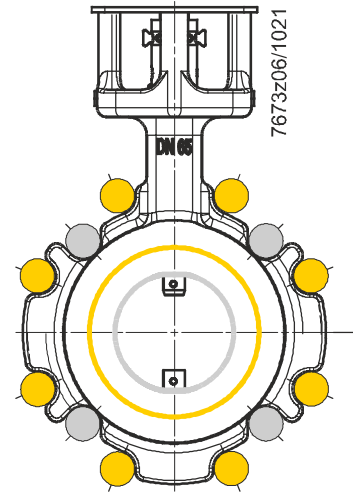
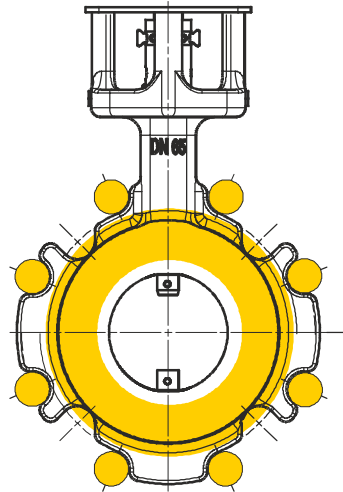
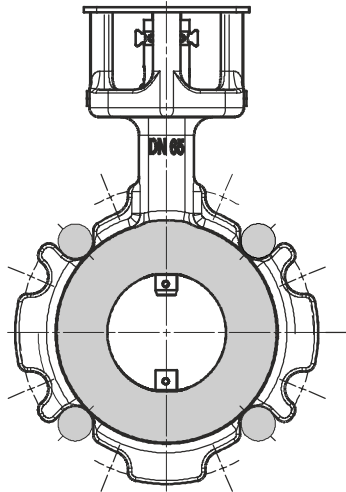

Nominal size	Swing thru	With mechanical stop	Suitable for flange size	Tightening torque	Mounting			
					DN ISO	DN ASME	DN+1 ISO	DN+1 ASME
32	VKF10.032	VKF11.032	DN32 + DN40	50 Nm	4 x M16	4 x 1/2	4 x M16	4 x 1/2
40	VKF10.040	VKF11.040	DN40 + DN50	50 Nm	4 x M16	4 x 1/2	4 x M16	4 x 5/8
50	VKF10.050	VKF11.050	DN50 + DN65	50 Nm	4 x M16	4 x 5/8	4 x M16	4 x 5/8
65	VKF10.065	VKF11.065	DN65 + DN80	50 Nm	4 x M16	4 x 5/8	8 x M16	4 x 5/8
80	VKF10.080	VKF11.080	DN80 + DN100	50 Nm	8 x M16	4 x 5/8	8 x M16	4 x 5/8
100	VKF10.100	VKF11.100	DN100 + DN125	80 Nm	8 x M16	8 x 5/8	8 x M16	8 x 3/4
125	VKF10.125	VKF11.125	DN125 + DN150	160 Nm	8 x M16	8 x 3/4	8 x M20	8 x 3/4
150	VKF10.150	VKF11.150	DN150 + DN200	160 Nm	8 x M20	8 x 3/4	12 x M20	8 x 3/4
200	VKF10.200	VKF11.200	DN200	160 Nm	12 x M20	8 x 3/4	---	---

Mounting position of the mounting plate

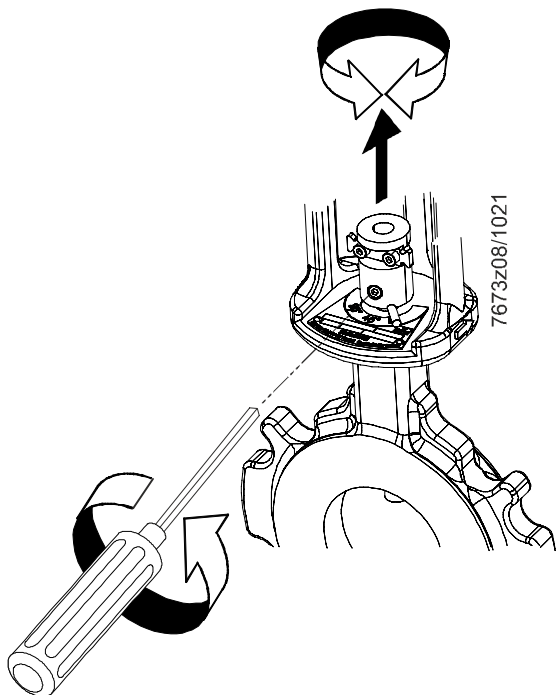
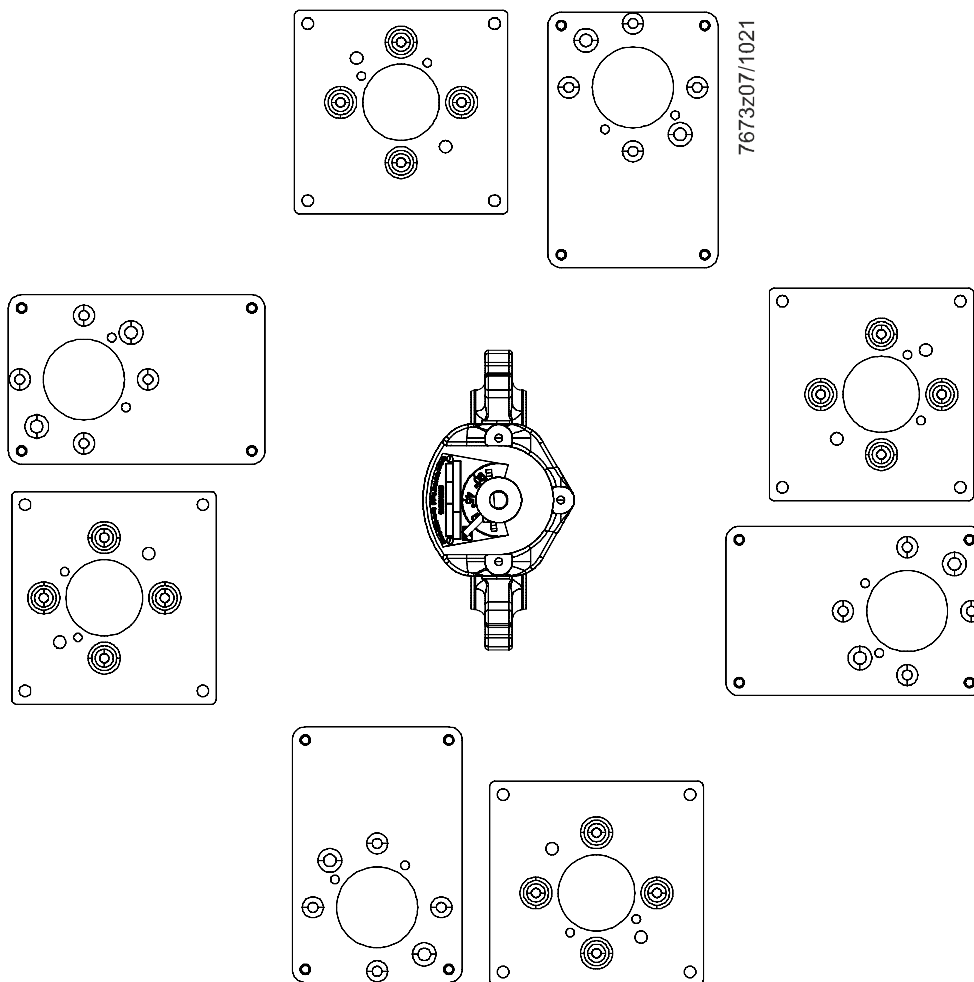

Loosen the screw. Align the coupling to suit the mounting position of the mounting plate. Tighten the screw again (max. 2 Nm).



Fitting the SQN72/SQN73 onto the VKF1x butterfly valve (continued)

Step 1:

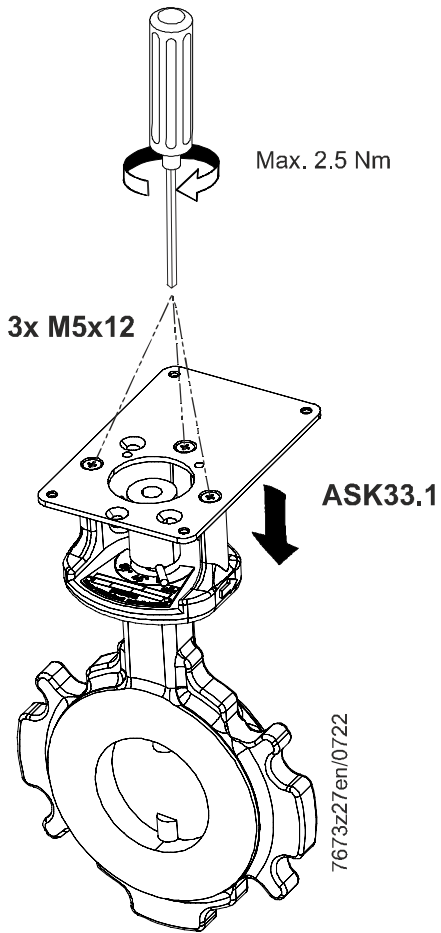

Step 2:

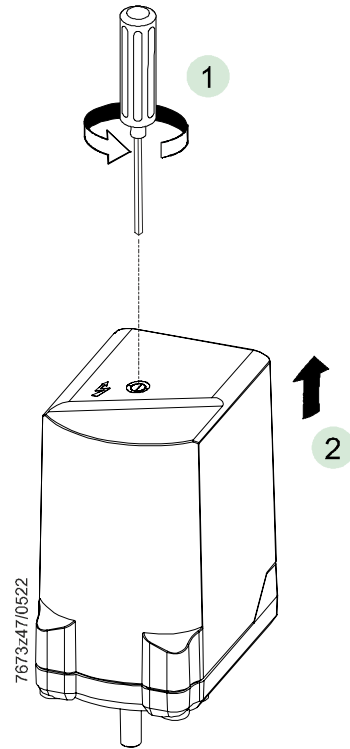

Step 3:

Release the coupling while pressing the pressure pin down

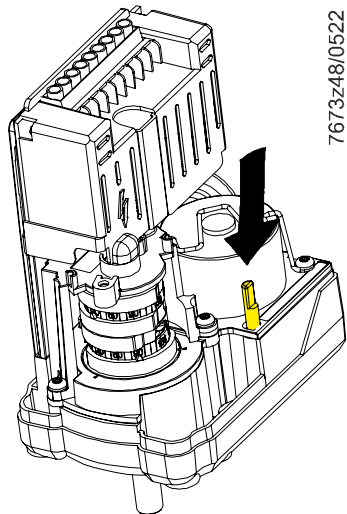

Step 4:

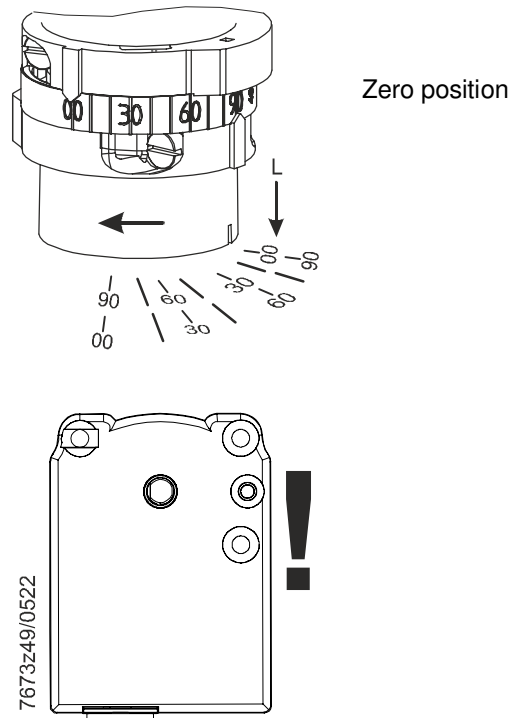

## Fitting the SQN72/SQN73 onto the VKF1x butterfly valve (continued)

### Step 5:

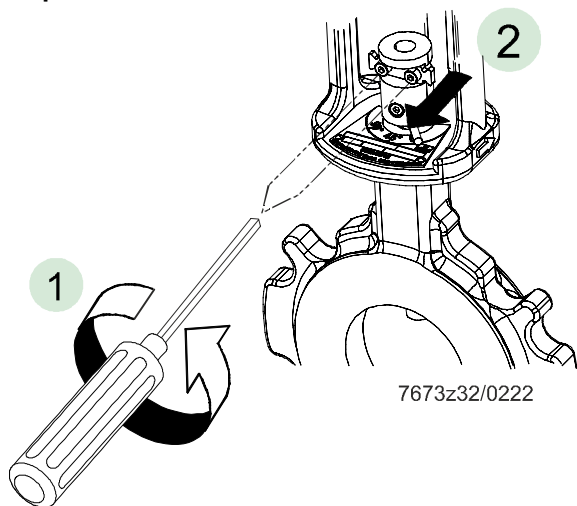

- 1 Loosen the screws.
- 2 Pull the plate in the direction of the arrow and mount the SQN72/SQN73

### Step 7:

Lock the coupling while loosening the pressure pin

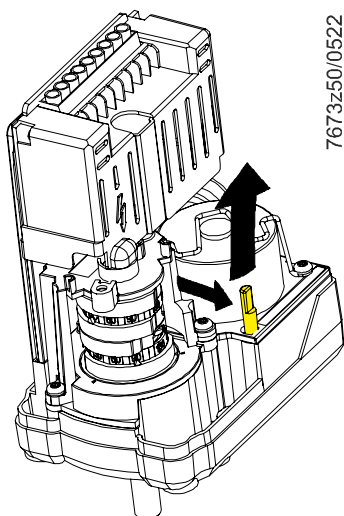

### Step 6:

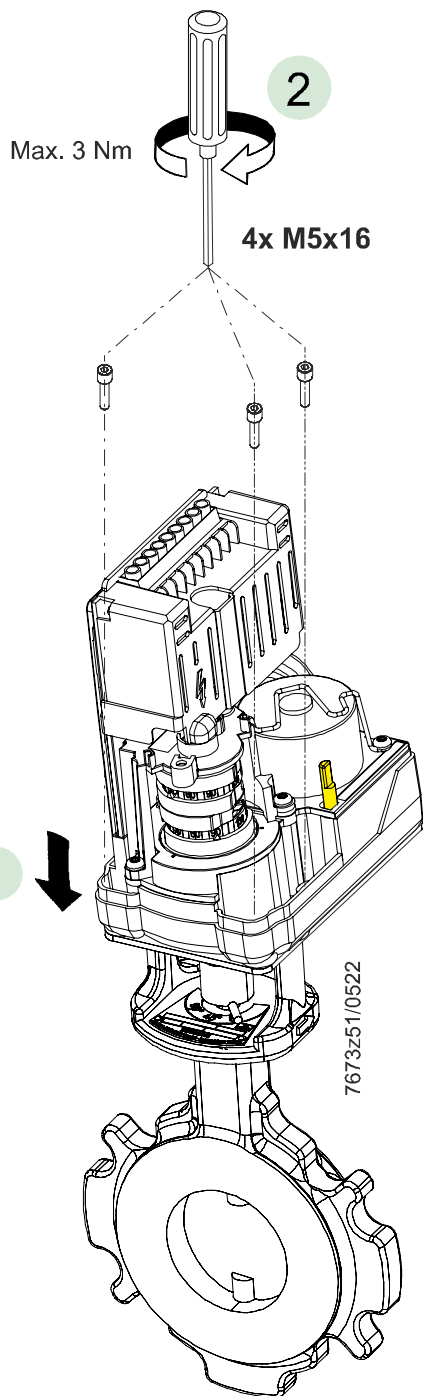

# Fitting the SQN72/SQN73 onto the VKF1x butterfly valve (continued)

## Step 8:

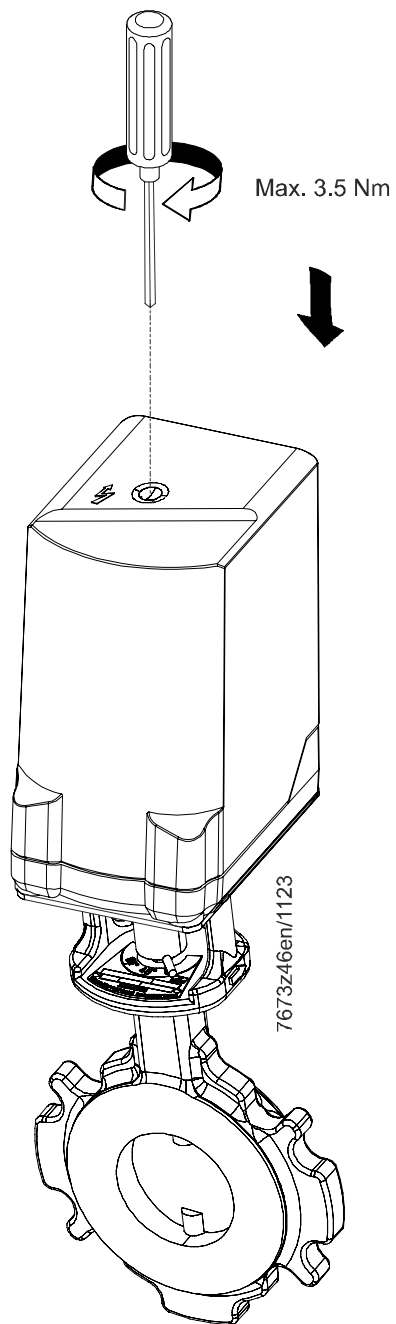

## Step 9:

Tighten the screws (max. 2 Nm).

